



## LINEA ACCIAIO INOSSIDABILE

### STAINLESS STEEL LINE



**PAG. 75** VULCANIZZATO IGIENICO • *HYGIENIC VULCANIZED*

**PAG. 89** VULCANIZZATO • *VULCANIZED*

**PAG. 105** LINEA 15° • *15° LINE*

**PAG. 115** MEDIA PORTATA • *MEDIUM LOAD*

**PAG. 129** CARICHI PESANTI 30° • *HEAVY DUTY 30°*

**PAG. 141** CARICHI PESANTI 10° • *HEAVY DUTY 10°*

**PAG. 145** CARICHI PESANTI 0° • *HEAVY DUTY 0°*

• Materiale base e stelo: acciaio inox AISI 304 (a richiesta AISI 316).  
Gomma NBR 80 shore. Stelo snodato 10°

• I valori dei carichi sopra riportati sono calcolati in condizioni statiche alla metà della lunghezza dello stelo filettato. Qualora s'intendesse utilizzare i supporti in presenza di vibrazioni o carichi in movimento, tali valori dovranno essere adeguatamente ridotti. Per ulteriori chiarimenti consultare il nostro ufficio tecnico. Ogni nostra responsabilità decade in caso di manomissioni o modifiche dei componenti.

• *Screw and base material: 1.4301 (1.4401 on request).*

• *Pad: vulcanized rubber NBR 80 shore. Articulated screw 10°*

• *Load values above mentioned have to be considered referring to static conditions calculated at the half of the screw length. In conditions of vibrations or in presence of dynamic loads these values should be reduced. For further information consult our technical office. We cannot accept responsibility for mounts that have been tampered or modified.*

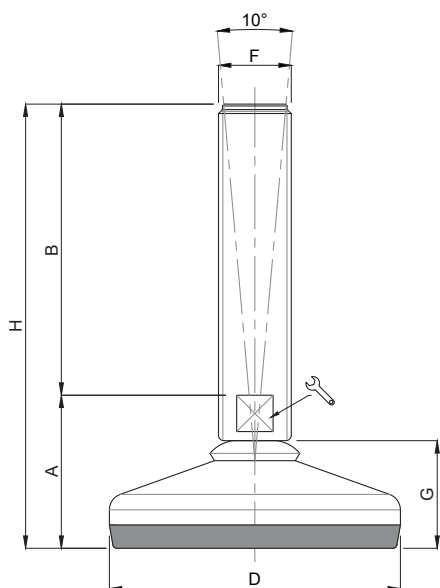

**NBR**



**EPDM**



CODICE - CODE		DESCRIZIONE description	DIMENSIONI PRINCIPALI - MAIN DIMENSIONS							CARICO LOAD NEWTON	
Gomma NBR	Gomma EPDM blu		A	B	D			F	G		H
24500R	24500RB	M10x50	32	50	ø 50	-	14	M10	24	82	4000
24502R	24502RB	M10x75	32	75	ø 50	-	14	M10	24	107	4000
24504R	24504RB	M10x100	32	100	ø 50	-	14	M10	24	132	4000
24506R	24506RB	M10x125	32	125	ø 50	-	14	M10	24	157	4000
24507R/BF	24507RB/BF	M10x150	35	150	ø 50	8	-	M10	24	185	4000
24508R/BF	24508RB/BF	M10x175	35	175	ø 50	8	-	M10	24	210	4000
24509R/BF	24509RB/BF	M10x200	35	200	ø 50	8	-	M10	24	235	4000
24600R	24600RB	M12x50	32	50	ø 50	-	14	M12	24	82	4000
24602R	24602RB	M12x75	32	75	ø 50	-	14	M12	24	107	4000
24604R	24604RB	M12x100	32	100	ø 50	-	14	M12	24	132	4000
24606R	24606RB	M12x125	32	125	ø 50	-	14	M12	24	157	4000
24607R/BF	24607RB/BF	M12x150	35	150	ø 50	10	-	M12	24	185	4000
24608R/BF	24608RB/BF	M12x175	35	175	ø 50	10	-	M12	24	210	4000
24609R/BF	24609RB/BF	M12x200	35	200	ø 50	10	-	M12	24	235	4000
24700R	24700RB	M14x75	32	75	ø 50	-	14	M14	24	107	4000
24702R	24702RB	M14x100	32	100	ø 50	-	14	M14	24	132	4000
24704R	24704RB	M14x125	32	125	ø 50	-	14	M14	24	157	4000
24706R	24706RB	M14x150	32	150	ø 50	-	14	M14	24	182	4000
24708R	24708RB	M14x175	32	175	ø 50	-	14	M14	24	207	4000
24800R	24800RB	M16x75	35	75	ø 50	13	-	M16	24	110	4000
24802R	24802RB	M16x100	35	100	ø 50	13	-	M16	24	135	4000
24804R	24804RB	M16x125	35	125	ø 50	13	-	M16	24	160	4000
24806R	24806RB	M16x150	35	150	ø 50	13	-	M16	24	185	4000
24808R	24808RB	M16x175	35	175	ø 50	13	-	M16	24	210	4000
24810R	24810RB	M16x200	35	200	ø 50	13	-	M16	24	235	4000

## Piede Inox

## VULCANIZZATO IGIENICO

Caratteristiche: BASE VULCANIZZATA Ø 60, STELO SNODATO 10°

Features: HYGIENIC VULCANIZED BASE Ø 60, 10° ARTICULATED STEM

**Martin**  
Levelling Components

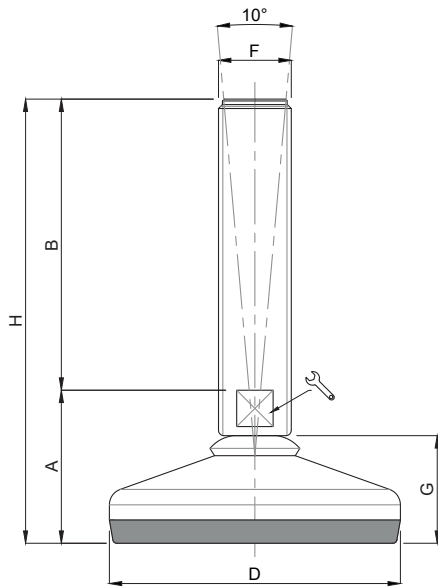

NBR



EPDM



INOX

CODICE - CODE		DESCRIZIONE description	DIMENSIONI PRINCIPALI - MAIN DIMENSIONS							CARICO LOAD NEWTON	
Gomma NBR	Gomma EPDM blu		A	B	D			F	G		H
24510R	24510RB	M10x50	35	50	ø 60	-	14	M10	27	85	7000
24512R	24512RB	M10x75	35	75	ø 60	-	14	M10	27	110	7000
24514R	24514RB	M10x100	35	100	ø 60	-	14	M10	27	135	7000
24516R	24516RB	M10x125	35	125	ø 60	-	14	M10	27	160	7000
24518R/BF	24518RB/BF	M10x150	40	150	ø 60	8	-	M10	27	190	7000
24520R/BF	24520RB/BF	M10x175	40	175	ø 60	8	-	M10	27	215	7000
24522R/BF	24522RB/BF	M10x200	40	200	ø 60	8	-	M10	27	240	7000
24610R	24610RB	M12x50	35	50	ø 60	-	14	M12	27	85	7000
24612R	24612RB	M12x75	35	75	ø 60	-	14	M12	27	110	7000
24614R	24614RB	M12x100	35	100	ø 60	-	14	M12	27	135	7000
24616R	24616RB	M12x125	35	125	ø 60	-	14	M12	27	160	7000
24618R/BF	24618RB/BF	M12x150	40	150	ø 60	10	-	M12	27	190	7000
24620R/BF	24620RB/BF	M12x175	40	175	ø 60	10	-	M12	27	215	7000
24622R/BF	24622RB/BF	M12x200	40	200	ø 60	10	-	M12	27	240	7000
24710R	24710RB	M14x75	35	75	ø 60	-	14	M14	27	110	7000
24712R	24712RB	M14x100	35	100	ø 60	-	14	M14	27	135	7000
24714R	24714RB	M14x125	35	125	ø 60	-	14	M14	27	160	7000
24716R	24716RB	M14x150	35	150	ø 60	-	14	M14	27	185	7000
24718R	24718RB	M14x175	35	175	ø 60	-	14	M14	27	210	7000
24814R	24814RB	M16x75	40	75	ø 60	13	-	M16	27	115	7000
24816R	24816RB	M16x100	40	100	ø 60	13	-	M16	27	140	7000
24818R	24818RB	M16x125	40	125	ø 60	13	-	M16	27	165	7000
24820R	24820RB	M16x150	40	150	ø 60	13	-	M16	27	190	7000
24822R	24822RB	M16x175	40	175	ø 60	13	-	M16	27	215	7000
24824R	24824RB	M16x200	40	200	ø 60	13	-	M16	27	240	7000
24910R	24910RB	M20x75	40	75	ø 60	17	-	M20	27	115	7000
24912R	24912RB	M20x100	40	100	ø 60	17	-	M20	27	140	7000
24914R	24914RB	M20x125	40	125	ø 60	17	-	M20	27	165	7000
24916R	24916RB	M20x150	40	150	ø 60	17	-	M20	27	190	7000
24918R	24918RB	M20x175	40	175	ø 60	17	-	M20	27	215	7000
24920R	24920RB	M20x200	40	200	ø 60	17	-	M20	27	240	7000
24922R	24922RB	M20x225	40	225	ø 60	17	-	M20	27	265	7000
24924R	24924RB	M20x250	40	250	ø 60	17	-	M20	27	290	7000

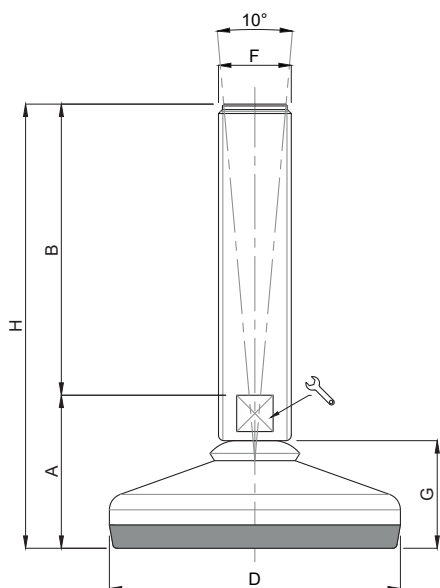

NBR

EPDM



CODICE - CODE		DESCRIZIONE description	DIMENSIONI PRINCIPALI - MAIN DIMENSIONS							CARICO LOAD NEWTON	
Gomma NBR	Gomma EPDM blu		A	B	D			F	G		H
24900/10R	24900/10RB	M10x50	37	50	ø 80	-	14	M10	30	87	10000
25000/10R	25000/10RB	M10x75	37	75	ø 80	-	14	M10	30	112	10000
25002/10R	25002/10RB	M10x100	37	100	ø 80	-	14	M10	30	137	10000
25004/10R	25004/10RB	M10x125	37	125	ø 80	-	14	M10	30	162	10000
25006/10R/BF	25006/10RB/BF	M10x150	42	150	ø 80	8	-	M10	30	192	10000
25008/10R/BF	25008/10RB/BF	M10x175	42	175	ø 80	8	-	M10	30	217	10000
25010/10R/BF	25010/10RB/BF	M10x200	42	200	ø 80	8	-	M10	30	242	10000
24900/12R	24900/12RB	M12x50	37	50	ø 80	-	14	M12	30	87	10000
25000/12R	25000/12RB	M12x75	37	75	ø 80	-	14	M12	30	112	10000
25002/12R	25002/12RB	M12x100	37	100	ø 80	-	14	M12	30	137	10000
25004/12R	25004/12RB	M12x125	37	125	ø 80	-	14	M12	30	162	10000
25006/12R/BF	25006/12RB/BF	M12x150	42	150	ø 80	10	-	M12	30	192	10000
25008/12R/BF	25008/12RB/BF	M12x175	42	175	ø 80	10	-	M12	30	217	10000
25010/12R/BF	25010/12RB/BF	M12x200	42	200	ø 80	10	-	M12	30	242	10000
25000R	25000RB	M14x75	35	75	ø 80	-	14	M14	30	110	10000
25002R	25002RB	M14x100	35	100	ø 80	-	14	M14	30	135	10000
25004R	25004RB	M14x125	35	125	ø 80	-	14	M14	30	160	10000
25006R	25006RB	M14x150	35	150	ø 80	-	14	M14	30	185	10000
25008R	25008RB	M14x175	35	175	ø 80	-	14	M14	30	210	10000
25020R	25020RB	M16x75	42	75	ø 80	13	-	M16	30	117	10000
25022R	25022RB	M16x100	42	100	ø 80	13	-	M16	30	142	10000
25024R	25024RB	M16x125	42	125	ø 80	13	-	M16	30	167	10000
25026R	25026RB	M16x150	42	150	ø 80	13	-	M16	30	192	10000
25028R	25028RB	M16x175	42	175	ø 80	13	-	M16	30	217	10000
25030R	25030RB	M16x200	42	200	ø 80	13	-	M16	30	242	10000
25040R	25040RB	M20x75	42	75	ø 80	17	-	M20	30	117	10000
25042R	25042RB	M20x100	42	100	ø 80	17	-	M20	30	142	10000
25044R	25044RB	M20x125	42	125	ø 80	17	-	M20	30	167	10000
25046R	25046RB	M20x150	42	150	ø 80	17	-	M20	30	192	10000
25048R	25048RB	M20x175	42	175	ø 80	17	-	M20	30	217	10000
25050R	25050RB	M20x200	42	200	ø 80	17	-	M20	30	242	10000
25052R	25052RB	M20x225	42	225	ø 80	17	-	M20	30	267	10000
25054R	25054RB	M20x250	42	250	ø 80	17	-	M20	30	292	10000
25070R	25070RB	M24x75	42	75	ø 80	20	-	M24	30	117	10000
25072R	25072RB	M24x100	42	100	ø 80	20	-	M24	30	142	10000
25074R	25074RB	M24x125	42	125	ø 80	20	-	M24	30	167	10000
* 25076R	25076RB	M24x150	42	150	ø 80	20	-	M24	30	192	10000
* 25078R	25078RB	M24x175	42	175	ø 80	20	-	M24	30	217	10000
* 25080R	25080RB	M24x200	42	200	ø 80	20	-	M24	30	242	10000
25082R	25082RB	M24x225	42	225	ø 80	20	-	M24	30	267	10000
25084R	25084RB	M24x250	42	250	ø 80	20	-	M24	30	292	10000

\* Disponibile con Filettatura a passo fine. Aggiungere "/P2" al codice  
Available with Thin pitch thread. Please, add "/P2" to the code.

# Piede Inox

# VULCANIZZATO IGIENICO

Caratteristiche: BASE VULCANIZZATA Ø 100, STELO SNODATO 10°

Features: HYGIENIC VULCANIZED BASE Ø 100, 10° ARTICULATED STEM

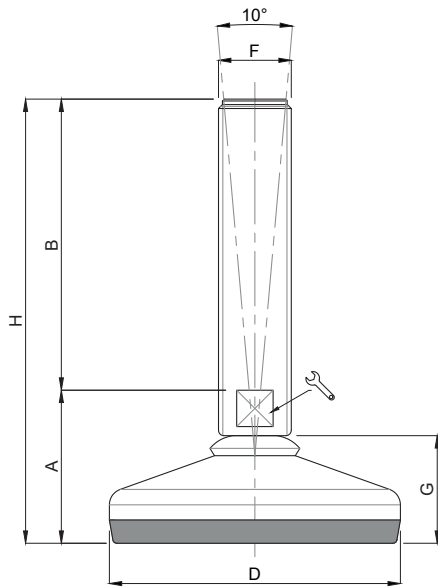

NBR

EPDM

CODICE - CODE		DESCRIZIONE description	DIMENSIONI PRINCIPALI - MAIN DIMENSIONS								CARICO LOAD NEWTON
Gomma NBR	Gomma EPDM blu		A	B	D			F	G	H	
25100R	25100RB	M16x75	46	75	Ø 100	13	-	M16	33	121	15000
25102R	25102RB	M16x100	46	100	Ø 100	13	-	M16	33	146	15000
25104R	25104RB	M16x125	46	125	Ø 100	13	-	M16	33	171	15000
25106R	25106RB	M16x150	46	150	Ø 100	13	-	M16	33	196	15000
25108R	25108RB	M16x175	46	175	Ø 100	13	-	M16	33	221	15000
25110R	25110RB	M16x200	46	200	Ø 100	13	-	M16	33	246	15000
25120R	25120RB	M20x75	46	75	Ø 100	17	-	M20	33	121	15000
25122R	25122RB	M20x100	46	100	Ø 100	17	-	M20	33	146	15000
25124R	25124RB	M20x125	46	125	Ø 100	17	-	M20	33	171	15000
25126R	25126RB	M20x150	46	150	Ø 100	17	-	M20	33	196	15000
25128R	25128RB	M20x175	46	175	Ø 100	17	-	M20	33	221	15000
25130R	25130RB	M20x200	46	200	Ø 100	17	-	M20	33	246	15000
25132R	25132RB	M20x225	46	225	Ø 100	17	-	M20	33	271	15000
25134R	25134RB	M20x250	46	250	Ø 100	17	-	M20	33	296	15000
25150R	25150RB	M24x100	48	100	Ø 100	20	-	M24	33	148	15000
25152R	25152RB	M24x125	48	125	Ø 100	20	-	M24	33	173	15000
* 25154R	25154RB	M24x150	48	150	Ø 100	20	-	M24	33	198	15000
* 25156R	25156RB	M24x175	48	175	Ø 100	20	-	M24	33	223	15000
* 25158R	25158RB	M24x200	48	200	Ø 100	20	-	M24	33	248	15000
25160R	25160RB	M24x225	48	225	Ø 100	20	-	M24	33	273	15000
25162R	25162RB	M24x250	48	250	Ø 100	20	-	M24	33	298	15000
25180R	25180RB	M30x100	48	100	Ø 100	-	26	M30	33	148	15000
25182R	25182RB	M30x125	48	125	Ø 100	-	26	M30	33	173	15000
* 25184R	25184RB	M30x150	48	150	Ø 100	-	26	M30	33	198	15000
* 25186R	25186RB	M30x175	48	175	Ø 100	-	26	M30	33	223	15000
* 25188R	25188RB	M30x200	48	200	Ø 100	-	26	M30	33	248	15000
25200R	25200RB	M30x225	48	225	Ø 100	-	26	M30	33	273	15000
25202R	25202RB	M30x250	48	250	Ø 100	-	26	M30	33	298	15000

\* Disponibile con Filettatura a passo fine. Aggiungere "/P2" al codice  
Available with Thin pitch thread. Please, add "/P2" to the code.

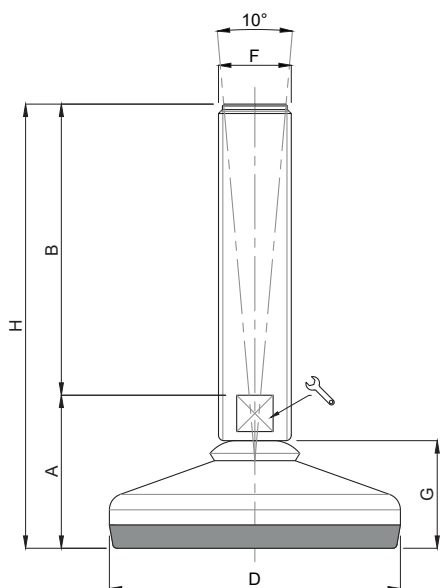

**NBR**



**EPDM**



CODICE - CODE		DESCRIZIONE description	DIMENSIONI PRINCIPALI - MAIN DIMENSIONS							CARICO LOAD NEWTON	
Gomma NBR	Gomma EPDM blu		A	B	D			F	G		H
25250R	25250RB	M16x75	49	75	Ø 120	13	-	M16	36	124	30000
25252R	25252RB	M16x100	49	100	Ø 120	13	-	M16	36	149	30000
25254R	25254RB	M16x125	49	125	Ø 120	13	-	M16	36	174	30000
25256R	25256RB	M16x150	49	150	Ø 120	13	-	M16	36	199	30000
25258R	25258RB	M16x175	49	175	Ø 120	13	-	M16	36	224	30000
25260R	25260RB	M16x200	49	200	Ø 120	13	-	M16	36	249	30000
25262R	25262RB	M20x75	49	75	Ø 120	17	-	M20	36	124	30000
25264R	25264RB	M20x100	49	100	Ø 120	17	-	M20	36	149	30000
25266R	25266RB	M20x125	49	125	Ø 120	17	-	M20	36	174	30000
25268R	25268RB	M20x150	49	150	Ø 120	17	-	M20	36	199	30000
25270R	25270RB	M20x175	49	175	Ø 120	17	-	M20	36	224	30000
25272R	25272RB	M20x200	49	200	Ø 120	17	-	M20	36	249	30000
25274R	25274RB	M20x225	49	225	Ø 120	17	-	M20	36	274	30000
25276R	25276RB	M20x250	49	250	Ø 120	17	-	M20	36	299	30000
25278R	25278RB	M24x100	51	100	Ø 120	20	-	M24	36	151	30000
25280R	25280R	M24x125	51	125	Ø 120	20	-	M24	36	176	30000
* 25282R	25282RB	M24x150	51	150	Ø 120	20	-	M24	36	201	30000
* 25284R	25284RB	M24x175	51	175	Ø 120	20	-	M24	36	226	30000
* 25286R	25286RB	M24x200	51	200	Ø 120	20	-	M24	36	251	30000
* 25288R	25288RB	M24x225	51	225	Ø 120	20	-	M24	36	276	30000
25290R	25290RB	M24x250	51	250	Ø 120	20	-	M24	36	301	30000
25292R	25292RB	M30x100	51	100	Ø 120	-	26	M30	36	151	30000
25294R	25294RB	M30x125	51	125	Ø 120	-	26	M30	36	176	30000
* 25296R	25296RB	M30x150	51	150	Ø 120	-	26	M30	36	201	30000
* 25298R	25298RB	M30x175	51	175	Ø 120	-	26	M30	36	226	30000
* 25300R	25300RB	M30x200	51	200	Ø 120	-	26	M30	36	251	30000
* 25302R	25302RB	M30x225	51	225	Ø 120	-	26	M30	36	276	30000
* 25304R	25304RB	M30x250	51	250	Ø 120	-	26	M30	36	301	30000

\* Disponibile con Filettatura a passo fine. Aggiungere "/P2" al codice  
Available with Thin pitch thread. Please, add "/P2" to the code.

# Piede Inox

# VULCANIZZATO IGIENICO



**Caratteristiche: BASE VULCANIZZATA Ø 60 CON FISSAGGIO, STELO SNODATO 10°**

**Features: HYGIENIC VULCANIZED BOLT/DOWN BASE Ø 60, 10° ARTICULATED STEM**

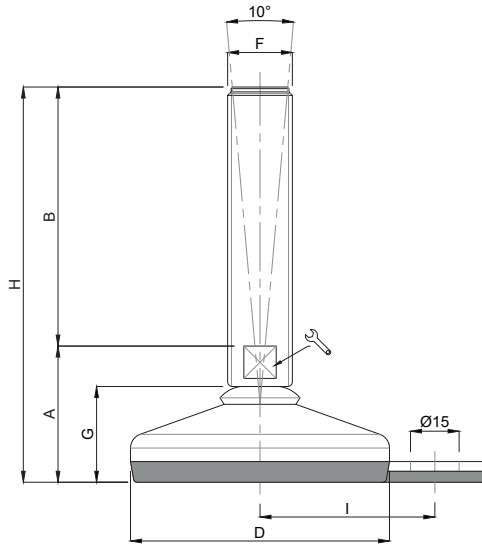

**NBR**



**EPDM**



CODICE - CODE		DESCRIZIONE description	DIMENSIONI PRINCIPALI - MAIN DIMENSIONS									CARICO LOAD NEWTON
Gomma NBR	Gomma EPDM blu		A	B	D			F	G	H	I	
24510R/F	24510RB/F	M10x50	35	50	Ø 60	-	14	M10	27	85	45	7000
24512R/F	24512RB/F	M10x75	35	75	Ø 60	-	14	M10	27	110	45	7000
24514R/F	24514RB/F	M10x100	35	100	Ø 60	-	14	M10	27	135	45	7000
24516R/F	24516RB/F	M10x125	35	125	Ø 60	-	14	M10	27	160	45	7000
24518R/BF/F	24518RB/BF/F	M10x150	40	150	Ø 60	8	-	M10	27	190	45	7000
24520R/BF/F	24520RB/BF/F	M10x175	40	175	Ø 60	8	-	M10	27	215	45	7000
24522R/BF/F	24522RB/BF/F	M10x200	40	200	Ø 60	8	-	M10	27	240	45	7000
24610R/F	24610RB/F	M12x50	35	50	Ø 60	-	14	M12	27	85	45	7000
24612R/F	24612RB/F	M12x75	35	75	Ø 60	-	14	M12	27	110	45	7000
24614R/F	24614RB/F	M12x100	35	100	Ø 60	-	14	M12	27	135	45	7000
24616R/F	24616RB/F	M12x125	35	125	Ø 60	-	14	M12	27	160	45	7000
24618R/BF/F	24618RB/BF/F	M12x150	40	150	Ø 60	10	-	M12	27	190	45	7000
24620R/BF/F	24620RB/BF/F	M12x175	40	175	Ø 60	10	-	M12	27	215	45	7000
24622R/BF/F	24622RB/BF/F	M12x200	40	200	Ø 60	10	-	M12	27	240	45	7000
24710R/F	24710RB/F	M14x75	35	75	Ø 60	-	14	M14	27	110	45	7000
24712R/F	24712RB/F	M14x100	35	100	Ø 60	-	14	M14	27	135	45	7000
24714R/F	24714RB/F	M14x125	35	125	Ø 60	-	14	M14	27	160	45	7000
24716R/F	24716RB/F	M14x150	35	150	Ø 60	-	14	M14	27	185	45	7000
24718R/F	24718RB/F	M14x175	35	175	Ø 60	-	14	M14	27	210	45	7000
24814R/F	24814RB/F	M16x75	40	75	Ø 60	13	-	M16	27	115	45	7000
24816R/F	24816RB/F	M16x100	40	100	Ø 60	13	-	M16	27	140	45	7000
24818R/F	24818RB/F	M16x125	40	125	Ø 60	13	-	M16	27	165	45	7000
24820R/F	24820RB/F	M16x150	40	150	Ø 60	13	-	M16	27	190	45	7000
24822R/F	24822RB/F	M16x175	40	175	Ø 60	13	-	M16	27	215	45	7000
24824R/F	24824RB/F	M16x200	40	200	Ø 60	13	-	M16	27	240	45	7000
24910R/F	24910RB/F	M20x75	40	75	Ø 60	17	-	M20	27	115	45	7000
24912R/F	24912RB/F	M20x100	40	100	Ø 60	17	-	M20	27	140	45	7000
24914R/F	24914RB/F	M20x125	40	125	Ø 60	17	-	M20	27	165	45	7000
24916R/F	24916RB/F	M20x150	40	150	Ø 60	17	-	M20	27	190	45	7000
24918R/F	24918RB/F	M20x175	40	175	Ø 60	17	-	M20	27	215	45	7000
24920R/F	24920RB/F	M20x200	40	200	Ø 60	17	-	M20	27	240	45	7000
24922R/F	24922RB/F	M20x225	40	225	Ø 60	17	-	M20	27	265	45	7000
24924R/F	24924RB/F	M20x250	40	250	Ø 60	17	-	M20	27	290	45	7000

INOX

**Caratteristiche: BASE VULCANIZZATA Ø 60 CON DOPPIO FISSAGGIO, STELO SNODATO 10°**

**Features: HYGIENIC VULCANIZED BOLT/DOWN BASE Ø 60, 10° ARTICULATED STEM**

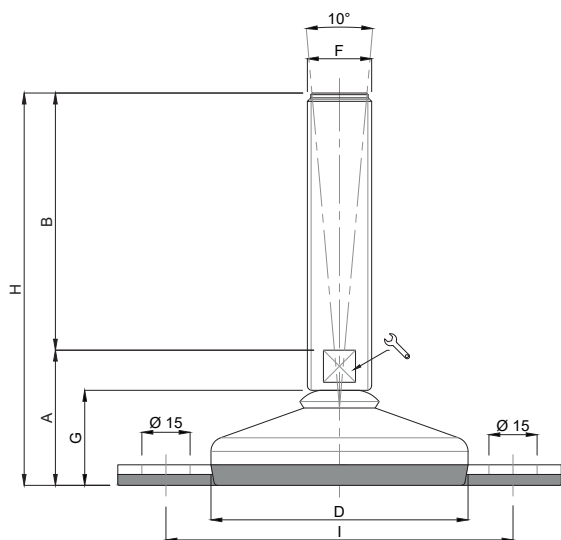

**NBR**



**EPDM**

Disponibile in Aisi 316 solo per gomma EPDM blu  
Aisi 316 Available only for blue EPDM

CODICE - CODE		DESCRIZIONE description	DIMENSIONI PRINCIPALI - MAIN DIMENSIONS								CARICO LOAD NEWTON	
Gomma NBR	Gomma EPDM blu		A	B	D			F	G	H		I
24510R/FF	24510RB/FF	M10x50	35	50	Ø 60	-	14	M10	27	85	90	7000
24512R/FF	24512RB/FF	M10x75	35	75	Ø 60	-	14	M10	27	110	90	7000
24514R/FF	24514RB/FF	M10x100	35	100	Ø 60	-	14	M10	27	135	90	7000
24516R/FF	24516RB/FF	M10x125	35	125	Ø 60	-	14	M10	27	160	90	7000
24518R/BF/FF	24518RB/BF/FF	M10x150	40	150	Ø 60	8	-	M10	27	190	90	7000
24520R/BF/FF	24520RB/BF/FF	M10x175	40	175	Ø 60	8	-	M10	27	215	90	7000
24522R/BF/FF	24522RB/BF/FF	M10x200	40	200	Ø 60	8	-	M10	27	240	90	7000
24610R/FF	24610RB/FF	M12x50	35	50	Ø 60	-	14	M12	27	85	90	7000
24612R/FF	24612RB/FF	M12x75	35	75	Ø 60	-	14	M12	27	110	90	7000
24614R/FF	24614RB/FF	M12x100	35	100	Ø 60	-	14	M12	27	135	90	7000
24616R/FF	24616RB/FF	M12x125	35	125	Ø 60	-	14	M12	27	160	90	7000
24618R/BF/FF	24618RB/BF/FF	M12x150	40	150	Ø 60	10	-	M12	27	190	90	7000
24620R/BF/FF	24620RB/BF/FF	M12x175	40	175	Ø 60	10	-	M12	27	215	90	7000
24622R/BF/FF	24622RB/BF/FF	M12x200	40	200	Ø 60	10	-	M12	27	240	90	7000
24710R/FF	24710RB/FF	M14x75	35	75	Ø 60	-	14	M14	27	110	90	7000
24712R/FF	24712RB/FF	M14x100	35	100	Ø 60	-	14	M14	27	135	90	7000
24714R/FF	24714RB/FF	M14x125	35	125	Ø 60	-	14	M14	27	160	90	7000
24716R/FF	24716RB/FF	M14x150	35	150	Ø 60	-	14	M14	27	185	90	7000
24718R/FF	24718RB/FF	M14x175	35	175	Ø 60	-	14	M14	27	210	90	7000
24814R/FF	24814RB/FF	M16x75	40	75	Ø 60	13	-	M16	27	115	90	7000
24816R/FF	24816RB/FF	M16x100	40	100	Ø 60	13	-	M16	27	140	90	7000
24818R/FF	24818RB/FF	M16x125	40	125	Ø 60	13	-	M16	27	165	90	7000
24820R/FF	24820RB/FF	M16x150	40	150	Ø 60	13	-	M16	27	190	90	7000
24822R/FF	24822RB/FF	M16x175	40	175	Ø 60	13	-	M16	27	215	90	7000
24824R/FF	24824RB/FF	M16x200	40	200	Ø 60	13	-	M16	27	240	90	7000
24910R/FF	24910RB/FF	M20x75	40	75	Ø 60	17	-	M20	27	115	90	7000
24912R/FF	24912RB/FF	M20x100	40	100	Ø 60	17	-	M20	27	140	90	7000
24914R/FF	24914RB/FF	M20x125	40	125	Ø 60	17	-	M20	27	165	90	7000
24916R/FF	24916RB/FF	M20x150	40	150	Ø 60	17	-	M20	27	190	90	7000
24918R/FF	24918RB/FF	M20x175	40	175	Ø 60	17	-	M20	27	215	90	7000
24920R/FF	24920RB/FF	M20x200	40	200	Ø 60	17	-	M20	27	240	90	7000
24922R/FF	24922RB/FF	M20x225	40	225	Ø 60	17	-	M20	27	265	90	7000
24924R/FF	24924RB/FF	M20x250	40	250	Ø 60	17	-	M20	27	290	90	7000

# Piede Inox

# VULCANIZZATO IGIENICO



Caratteristiche: BASE VULCANIZZATA Ø 80 CON FISSAGGIO, STELO SNODATO 10°

Features: HYGIENIC VULCANIZED BOLT/DOWN BASE Ø 80, 10° ARTICULATED STEM

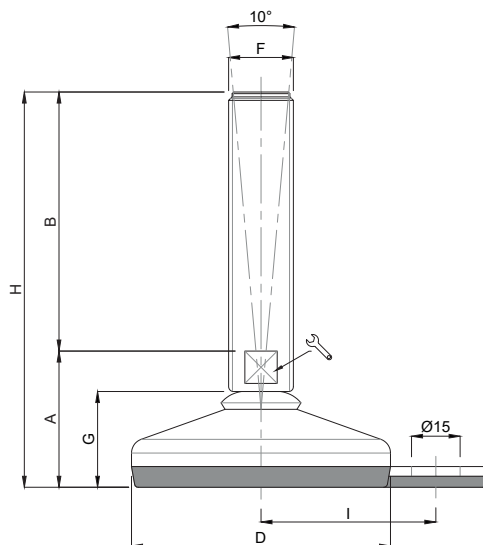

NBR



EPDM



INOX

CODICE - CODE		DESCRIZIONE description	DIMENSIONI PRINCIPALI - MAIN DIMENSIONS									CARICO LOAD NEWTON
Gomma NBR	Gomma EPDM blu		A	B	D			F	G	H	I	
24900/10R/F	24900/10RB/F	M10x50	37	50	ø 80	-	14	M10	30	87	54	10000
25000/10R/F	25000/10RB/F	M10x75	37	75	ø 80	-	14	M10	30	112	54	10000
25002/10R/F	25002/10RB/F	M10x100	37	100	ø 80	-	14	M10	30	137	54	10000
25004/10R/F	25004/10RB/F	M10x125	37	125	ø 80	-	14	M10	30	162	54	10000
25006/10R/BF/F	25006/10RB/BF/F	M10x150	42	150	ø 80	8	-	M10	30	192	54	10000
25008/10R/BF/F	25008/10RB/BF/F	M10x175	42	175	ø 80	8	-	M10	30	217	54	10000
25010/10R/BF/F	25010/10RB/BF/F	M10x200	42	200	ø 80	8	-	M10	30	242	54	10000
24900/12R/F	24900/12RB/F	M12x50	37	50	ø 80	-	14	M12	30	87	54	10000
25000/12R/F	25000/12RB/F	M12x75	37	75	ø 80	-	14	M12	30	112	54	10000
25002/12R/F	25002/12RB/F	M12x100	37	100	ø 80	-	14	M12	30	137	54	10000
25004/12R/F	25004/12RB/F	M12x125	37	125	ø 80	-	14	M12	30	162	54	10000
25006/12R/BF/F	25006/12RB/BF/F	M12x150	42	150	ø 80	10	-	M12	30	192	54	10000
25008/12R/BF/F	25008/12RB/BF/F	M12x175	42	175	ø 80	10	-	M12	30	217	54	10000
25010/12R/BF/F	25010/12RB/BF/F	M12x200	42	200	ø 80	10	-	M12	30	242	54	10000
25000R/F	25000RB/F	M14x75	35	75	ø 80	-	14	M14	30	110	54	10000
25002R/F	25002RB/F	M14x100	35	100	ø 80	-	14	M14	30	135	54	10000
25004R/F	25004RB/F	M14x125	35	125	ø 80	-	14	M14	30	160	54	10000
25006R/F	25006RB/F	M14x150	35	150	ø 80	-	14	M14	30	185	54	10000
25008R/F	25008RB/F	M14x175	35	175	ø 80	-	14	M14	30	210	54	10000
25020R/F	25020RB/F	M16x75	42	75	ø 80	13	-	M16	30	117	54	10000
25022R/F	25022RB/F	M16x100	42	100	ø 80	13	-	M16	30	142	54	10000
25024R/F	25024RB/F	M16x125	42	125	ø 80	13	-	M16	30	167	54	10000
25026R/F	25026RB/F	M16x150	42	150	ø 80	13	-	M16	30	192	54	10000
25028R/F	25028RB/F	M16x175	42	175	ø 80	13	-	M16	30	217	54	10000
25030R/F	25030RB/F	M16x200	42	200	ø 80	13	-	M16	30	242	54	10000
25040R/F	25040RB/F	M20x75	42	75	ø 80	17	-	M20	30	117	54	10000
25042R/F	25042RB/F	M20x100	42	100	ø 80	17	-	M20	30	142	54	10000
25044R/F	25044RB/F	M20x125	42	125	ø 80	17	-	M20	30	167	54	10000
25046R/F	25046RB/F	M20x150	42	150	ø 80	17	-	M20	30	192	54	10000
25048R/F	25048RB/F	M20x175	42	175	ø 80	17	-	M20	30	217	54	10000
25050R/F	25050RB/F	M20x200	42	200	ø 80	17	-	M20	30	242	54	10000
25052R/F	25052RB/F	M20x225	42	225	ø 80	17	-	M20	30	267	54	10000
25054R/F	25054RB/F	M20x250	42	250	ø 80	17	-	M20	30	292	54	10000
25070R/F	25070RB/F	M24x75	42	75	ø 80	20	-	M24	30	117	54	10000
25072R/F	25072RB/F	M24x100	42	100	ø 80	20	-	M24	30	142	54	10000
25074R/F	25074RB/F	M24x125	42	125	ø 80	20	-	M24	30	167	54	10000
* 25076R/F	25076RB/F	M24x150	42	150	ø 80	20	-	M24	30	192	54	10000
* 25078R/F	25078RB/F	M24x175	42	175	ø 80	20	-	M24	30	217	54	10000
* 25080R/F	25080RB/F	M24x200	42	200	ø 80	20	-	M24	30	242	54	10000
25082R/F	25082RB/F	M24x225	42	225	ø 80	20	-	M24	30	267	54	10000
25084R/F	25084RB/F	M24x250	42	250	ø 80	20	-	M24	30	292	54	10000

\* Disponibile con Filettatura a passo fine. Aggiungere "/P2" al codice  
Available with Thin pitch thread. Please, add "/P2" to the code.

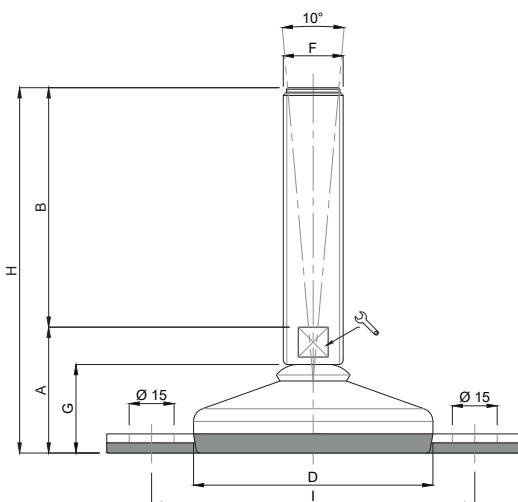

CODICE - CODE		DESCRIZIONE description	DIMENSIONI PRINCIPALI - MAIN DIMENSIONS								CARICO LOAD NEWTON	
Gomma NBR	Gomma EPDM blu		A	B	D			F	G	H		I
24900/10R/FF	24900/10RB/FF	M10x50	37	50	ø 80	-	14	M10	30	87	108	10000
25000/10R/FF	25000/10RB/FF	M10x75	37	75	ø 80	-	14	M10	30	112	108	10000
25002/10R/FF	25002/10RB/FF	M10x100	37	100	ø 80	-	14	M10	30	137	108	10000
25004/10R/FF	25004/10RB/FF	M10x125	37	125	ø 80	-	14	M10	30	162	108	10000
25006/10R/BF/FF	25006/10RB/BF/FF	M10x150	42	150	ø 80	8	-	M10	30	192	108	10000
25008/10R/BF/FF	25008/10RB/BF/FF	M10x175	42	175	ø 80	8	-	M10	30	217	108	10000
25010/10R/BF/FF	25010/10RB/BF/FF	M10x200	42	200	ø 80	8	-	M10	30	242	108	10000
24900/12R/FF	24900/12RB/FF	M12x50	37	50	ø 80	-	14	M12	30	87	108	10000
25000/12R/FF	25000/12RB/FF	M12x75	37	75	ø 80	-	14	M12	30	112	108	10000
25002/12R/FF	25002/12RB/FF	M12x100	37	100	ø 80	-	14	M12	30	137	108	10000
25004/12R/FF	25004/12RB/FF	M12x125	37	125	ø 80	-	14	M12	30	162	108	10000
25006/12R/BF/FF	25006/12RB/BF/FF	M12x150	42	150	ø 80	10	-	M12	30	192	108	10000
25008/12R/BF/FF	25008/12RB/BF/FF	M12x175	42	175	ø 80	10	-	M12	30	217	108	10000
25010/12R/BF/FF	25010/12RB/BF/FF	M12x200	42	200	ø 80	10	-	M12	30	242	108	10000
25000R/FF	25000RB/FF	M14x75	35	75	ø 80	-	14	M14	30	110	108	10000
25002R/FF	25002RB/FF	M14x100	35	100	ø 80	-	14	M14	30	135	108	10000
25004R/FF	25004RB/FF	M14x125	35	125	ø 80	-	14	M14	30	160	108	10000
25006R/FF	25006RB/FF	M14x150	35	150	ø 80	-	14	M14	30	185	108	10000
25008R/FF	25008RB/FF	M14x175	35	175	ø 80	-	14	M14	30	210	108	10000
25020R/FF	25020RB/FF	M16x75	42	75	ø 80	13	-	M16	30	117	108	10000
25022R/FF	25022RB/FF	M16x100	42	100	ø 80	13	-	M16	30	142	108	10000
25024R/FF	25024RB/FF	M16x125	42	125	ø 80	13	-	M16	30	167	108	10000
25026R/FF	25026RB/FF	M16x150	42	150	ø 80	13	-	M16	30	192	108	10000
25028R/FF	25028RB/FF	M16x175	42	175	ø 80	13	-	M16	30	217	108	10000
25030R/FF	25030RB/FF	M16x200	42	200	ø 80	13	-	M16	30	242	108	10000
25040R/FF	25040RB/FF	M20x75	42	75	ø 80	17	-	M20	30	117	108	10000
25042R/FF	25042RB/FF	M20x100	42	100	ø 80	17	-	M20	30	142	108	10000
25044R/FF	25044RB/FF	M20x125	42	125	ø 80	17	-	M20	30	167	108	10000
25046R/FF	25046RB/FF	M20x150	42	150	ø 80	17	-	M20	30	192	108	10000
25048R/FF	25048RB/FF	M20x175	42	175	ø 80	17	-	M20	30	217	108	10000
25050R/FF	25050RB/FF	M20x200	42	200	ø 80	17	-	M20	30	242	108	10000
25052R/FF	25052RB/FF	M20x225	42	225	ø 80	17	-	M20	30	267	108	10000
25054R/FF	25054RB/FF	M20x250	42	250	ø 80	17	-	M20	30	292	108	10000
25070R/FF	25070RB/FF	M24x75	42	75	ø 80	20	-	M24	30	117	108	10000
25072R/FF	25072RB/FF	M24x100	42	100	ø 80	20	-	M24	30	142	108	10000
25074R/FF	25074RB/FF	M24x125	42	125	ø 80	20	-	M24	30	167	108	10000
* 25076R/FF	25076RB/FF	M24x150	42	150	ø 80	20	-	M24	30	192	108	10000
* 25078R/FF	25078RB/FF	M24x175	42	175	ø 80	20	-	M24	30	217	108	10000
* 25080R/FF	25080RB/FF	M24x200	42	200	ø 80	20	-	M24	30	242	108	10000
* 25082R/FF	25082RB/FF	M24x225	42	225	ø 80	20	-	M24	30	267	108	10000
* 25084R/FF	25084RB/FF	M24x250	42	250	ø 80	20	-	M24	30	292	108	10000

\* Disponibile con Filettatura a passo fine. Aggiungere "/P2" al codice - Available with Thin pitch thread. Please, add "/P2" to the code.

## Piede Inox

## VULCANIZZATO IGIENICO

Martin  
Levelling Components

Caratteristiche: BASE VULCANIZZATA Ø 100 CON FISSAGGIO,  
STELO SNODATO 10°

Features: HYGIENIC VULCANIZED BOLT/DOWN BASE Ø 100,  
10° ARTICULATED STEM

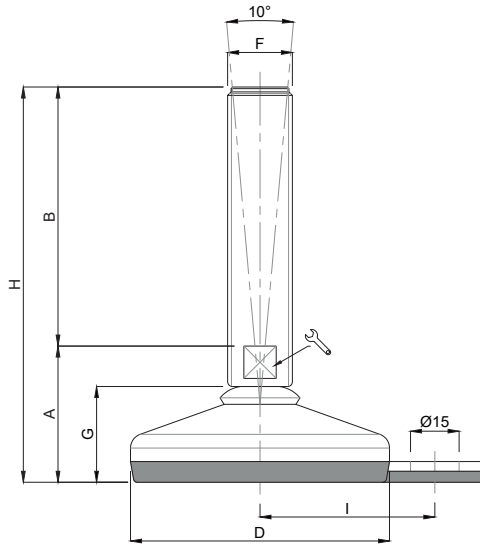

Disponibile in  
Aisi 316 solo per  
gomma EPDM blu  
Aisi 316 Available  
only for blue  
EPDM

NBR

EPDM

INOX

CODICE - CODE		DESCRIZIONE description	DIMENSIONI PRINCIPALI - MAIN DIMENSIONS									CARICO LOAD NEWTON
Gomma NBR	Gomma EPDM blu		A	B	D			F	G	H	I	
25100R/F	25100RB/F	M16x75	46	75	Ø 100	13	-	M16	33	121	69	15000
25102R/F	25102RB/F	M16x100	46	100	Ø 100	13	-	M16	33	146	69	15000
25104R/F	25104RB/F	M16x125	46	125	Ø 100	13	-	M16	33	171	69	15000
25106R/F	25106RB/F	M16x150	46	150	Ø 100	13	-	M16	33	196	69	15000
25108R/F	25108RB/F	M16x175	46	175	Ø 100	13	-	M16	33	221	69	15000
25110R/F	25110RB/F	M16x200	46	200	Ø 100	13	-	M16	33	246	69	15000
25120R/F	25120RB/F	M20x75	46	75	Ø 100	17	-	M20	33	121	69	15000
25122R/F	25122RB/F	M20x100	46	100	Ø 100	17	-	M20	33	146	69	15000
25124R/F	25124RB/F	M20x125	46	125	Ø 100	17	-	M20	33	171	69	15000
25126R/F	25126RB/F	M20x150	46	150	Ø 100	17	-	M20	33	196	69	15000
25128R/F	25128RB/F	M20x175	46	175	Ø 100	17	-	M20	33	221	69	15000
25130R/F	25130RB/F	M20x200	46	200	Ø 100	17	-	M20	33	246	69	15000
25132R/F	25132RB/F	M20x225	46	225	Ø 100	17	-	M20	33	271	69	15000
25134R/F	25134RB/F	M20x250	46	250	Ø 100	17	-	M20	33	296	69	15000
25150R/F	25150RB/F	M24x100	48	100	Ø 100	20	-	M24	33	148	69	15000
25152R/F	25152RB/F	M24x125	48	125	Ø 100	20	-	M24	33	173	69	15000
* 25154R/F	25154RB/F	M24x150	48	150	Ø 100	20	-	M24	33	198	69	15000
* 25156R/F	25156RB/F	M24x175	48	175	Ø 100	20	-	M24	33	223	69	15000
* 25158R/F	25158RB/F	M24x200	48	200	Ø 100	20	-	M24	33	248	69	15000
25160R/F	25160RB/F	M24x225	48	225	Ø 100	20	-	M24	33	273	69	15000
25162R/F	25162RB/F	M24x250	48	250	Ø 100	20	-	M24	33	298	69	15000
25180R/F	25180RB/F	M30x100	48	100	Ø 100	-	26	M30	33	148	69	15000
25182R/F	25182RB/F	M30x125	48	125	Ø 100	-	26	M30	33	173	69	15000
* 25184R/F	25184RB/F	M30x150	48	150	Ø 100	-	26	M30	33	198	69	15000
* 25186R/F	25186RB/F	M30x175	48	175	Ø 100	-	26	M30	33	223	69	15000
* 25188R/F	25188RB/F	M30x200	48	200	Ø 100	-	26	M30	33	248	69	15000
25200R/F	25200RB/F	M30x225	48	225	Ø 100	-	26	M30	33	273	69	15000
25202R/F	25202RB/F	M30x250	48	250	Ø 100	-	26	M30	33	298	69	15000

\* Disponibile con Filettatura a passo fine. Aggiungere "/P2" al codice  
Available with Thin pitch thread. Please, add "/P2" to the code.

**Caratteristiche: BASE VULCANIZZATA Ø 120 CON FISSAGGIO, STELO SNODATO 10°**

**Features: HYGIENIC VULCANIZED BOLT/DOWN BASE Ø 120, 10° ARTICULATED STEM**

Disponibile in Aisi 316 solo per gomma EPDM blu  
Aisi 316 Available only for blue EPDM

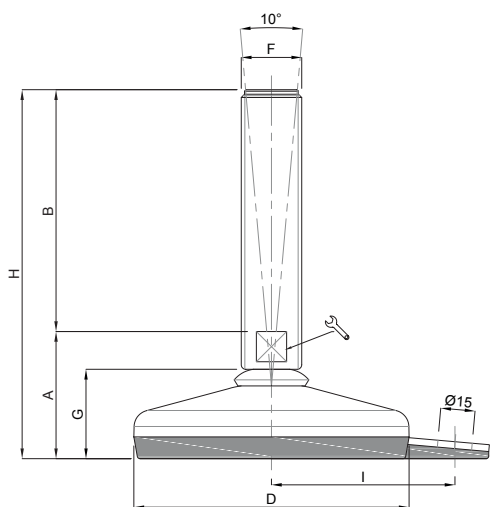

**NBR**

**EPDM**

CODICE - CODE		DESCRIZIONE description	DIMENSIONI PRINCIPALI - MAIN DIMENSIONS									CARICO LOAD NEWTON
Gomma NBR	Gomma EPDM blu		A	B	D			F	G	H	I	
25250R/F	25250RB/F	M16x75	49	75	Ø 120	13	-	M16	36	124	80	30000
25252R/F	25252RB/F	M16x100	49	100	Ø 120	13	-	M16	36	149	80	30000
25254R/F	25254RB/F	M16x125	49	125	Ø 120	13	-	M16	36	174	80	30000
25256R/F	25256RB/F	M16x150	49	150	Ø 120	13	-	M16	36	199	80	30000
25258R/F	25258RB/F	M16x175	49	175	Ø 120	13	-	M16	36	224	80	30000
25260R/F	25260RB/F	M16x200	49	200	Ø 120	13	-	M16	36	249	80	30000
25262R/F	25262RB/F	M20x75	49	75	Ø 120	17	-	M20	36	124	80	30000
25264R/F	25264RB/F	M20x100	49	100	Ø 120	17	-	M20	36	149	80	30000
25266R/F	25266RB/F	M20x125	49	125	Ø 120	17	-	M20	36	174	80	30000
25268R/F	25268RB/F	M20x150	49	150	Ø 120	17	-	M20	36	199	80	30000
25270R/F	25270RB/F	M20x175	49	175	Ø 120	17	-	M20	36	224	80	30000
25272R/F	25272RB/F	M20x200	49	200	Ø 120	17	-	M20	36	249	80	30000
25274R/F	25274RB/F	M20x225	49	225	Ø 120	17	-	M20	36	274	80	30000
25276R/F	25276RB/F	M20x250	49	250	Ø 120	17	-	M20	36	299	80	30000
25278R/F	25278RB/F	M24x100	51	100	Ø 120	20	-	M24	36	151	80	30000
25280R/F	25280R/F	M24x125	51	125	Ø 120	20	-	M24	36	176	80	30000
* 25282R/F	25282RB/F	M24x150	51	150	Ø 120	20	-	M24	36	201	80	30000
* 25284R/F	25284RB/F	M24x175	51	175	Ø 120	20	-	M24	36	226	80	30000
* 25286R/F	25286RB/F	M24x200	51	200	Ø 120	20	-	M24	36	251	80	30000
* 25288R/F	25288RB/F	M24x225	51	225	Ø 120	20	-	M24	36	276	80	30000
* 25290R/F	25290RB/F	M24x250	51	250	Ø 120	20	-	M24	36	301	80	30000
* 25292R/F	25292RB/F	M30x100	51	100	Ø 120	-	26	M30	36	151	80	30000
* 25294R/F	25294RB/F	M30x125	51	125	Ø 120	-	26	M30	36	176	80	30000
* 25296R/F	25296RB/F	M30x150	51	150	Ø 120	-	26	M30	36	201	80	30000
* 25298R/F	25298RB/F	M30x175	51	175	Ø 120	-	26	M30	36	226	80	30000
* 25300R/F	25300RB/F	M30x200	51	200	Ø 120	-	26	M30	36	251	80	30000
* 25302R/F	25302RB/F	M30x225	51	225	Ø 120	-	26	M30	36	276	80	30000
* 25304R/F	25304RB/F	M30x250	51	250	Ø 120	-	26	M30	36	301	80	30000

\* Disponibile con Filettatura a passo fine. Aggiungere "/P2" al codice  
Available with Thin pitch thread. Please, add "/P2" to the code.

## Piede Inox

## VULCANIZZATO IGIENICO



Caratteristiche: BASE VULCANIZZATA Ø 120 CON DOPPIO FISSAGGIO, STELO SNODATO 10°

Features: HYGIENIC VULCANIZED BOLT/DOWN BASE Ø 120, DOUBLE FIXING, 10° ARTICULATED STEM

Martin  
Levelling Components

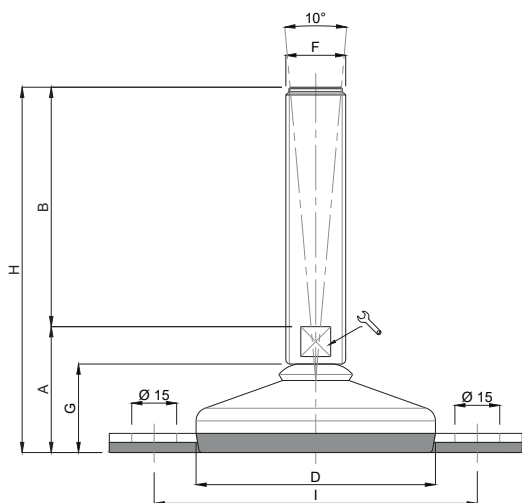
INOX



CODICE - CODE	DESCRIZIONE description	DIMENSIONI PRINCIPALI - MAIN DIMENSIONS									CARICO LOAD NEWTON
		A	B	D			F	G	H	I	
25250R/FF	M16x75	49	75	Ø 120	13	-	M16	36	124	160	30000
25252R/FF	M16x100	49	100	Ø 120	13	-	M16	36	149	160	30000
25254R/FF	M16x125	49	125	Ø 120	13	-	M16	36	174	160	30000
25256R/FF	M16x150	49	150	Ø 120	13	-	M16	36	199	160	30000
25258R/FF	M16x175	49	175	Ø 120	13	-	M16	36	224	160	30000
25260R/FF	M16x200	49	200	Ø 120	13	-	M16	36	249	160	30000
25262R/FF	M20x75	49	75	Ø 120	17	-	M20	36	124	160	30000
25264R/FF	M20x100	49	100	Ø 120	17	-	M20	36	149	160	30000
25266R/FF	M20x125	49	125	Ø 120	17	-	M20	36	174	160	30000
25268R/FF	M20x150	49	150	Ø 120	17	-	M20	36	199	160	30000
25270R/FF	M20x175	49	175	Ø 120	17	-	M20	36	224	160	30000
25272R/FF	M20x200	49	200	Ø 120	17	-	M20	36	249	160	30000
25274R/FF	M20x225	49	225	Ø 120	17	-	M20	36	274	160	30000
25276R/FF	M20x250	49	250	Ø 120	17	-	M20	36	299	160	30000
25278R/FF	M24x100	51	100	Ø 120	20	-	M24	36	151	160	30000
25280R/FF	M24x125	51	125	Ø 120	20	-	M24	36	176	160	30000
* 25282R/FF	M24x150	51	150	Ø 120	20	-	M24	36	201	160	30000
* 25284R/FF	M24x175	51	175	Ø 120	20	-	M24	36	226	160	30000
* 25286R/FF	M24x200	51	200	Ø 120	20	-	M24	36	251	160	30000
25288R/FF	M24x225	51	225	Ø 120	20	-	M24	36	276	160	30000
25290R/FF	M24x250	51	250	Ø 120	20	-	M24	36	301	160	30000
25292R/FF	M30x100	51	100	Ø 120	-	26	M30	36	151	160	30000
25294R/FF	M30x125	51	125	Ø 120	-	26	M30	36	176	160	30000
* 25296R/FF	M30x150	51	150	Ø 120	-	26	M30	36	201	160	30000
25298R/FF	M30x175	51	175	Ø 120	-	26	M30	36	226	160	30000
* 25300R/FF	M30x200	51	200	Ø 120	-	26	M30	36	251	160	30000
25302R/FF	M30x225	51	225	Ø 120	-	26	M30	36	276	160	30000
25304R/FF	M30x250	51	250	Ø 120	-	26	M30	36	301	160	30000

\* Disponibile con Filettatura a passo fine. Aggiungere "/P2" al codice  
Available with Thin pitch thread. Please, add "/P2" to the code.



## LINEA VULCANIZZATA *VULCANIZED LINE*

- Materiale base e stelo: acciaio inox AISI 304 (a richiesta AISI 316).  
Gomma NBR 80 shore  
Stelo snodato 10°
- I valori dei carichi sopra riportati sono calcolati in condizioni statiche alla metà della lunghezza dello stelo filettato. Qualora s'intendesse utilizzare i supporti in presenza di vibrazioni o carichi in movimento, tali valori dovranno essere adeguatamente ridotti. Per ulteriori chiarimenti consultare il nostro ufficio tecnico. Ogni nostra responsabilità decade in caso di manomissioni o modifiche dei componenti.
- *Screw and base material: 1.4301 (1.4401 on request).  
Pad: vulcanized rubber NBR 80 shore  
Articulated screw 10°*
- *Load values above mentioned have to be considered referring to static conditions calculated at the half of the screw length. In conditions of vibrations or in presence of dynamic loads these values should be reduced. For further information consult our technical office. We cannot accept responsibility for mounts that have been tampered or modified*

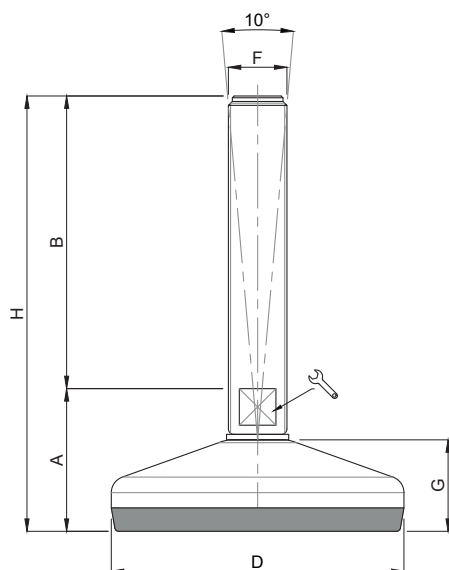

**ESAGONO INTERNO IN TESTA  
TOP INTERNAL HEX**

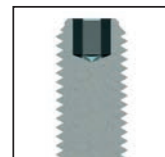

**AGGIUNGI AL CODICE  
ADD TO CODE**

CODICE - CODE	F	HEX
.../TIH5	M10	5
.../TIH6	M12	6
.../TIH8	M16	8
.../TIH10	M20/M24/M30	10

A richiesta - On request



CODICE CODE	DESCRIZIONE description	DIMENSIONI PRINCIPALI - MAIN DIMENSIONS							CARICO LOAD NEWTON
		A	B	D		F	G	H	
24400	M8x25	26	25	ø 40	6	M8	15	51	3000
24402	M8x50	26	50	ø 40	6	M8	15	76	3000
24404	M8x75	26	75	ø 40	6	M8	15	101	3000
24406	M10x25	26	25	ø 40	8	M10	15	51	3000
24408	M10x50	26	50	ø 40	8	M10	15	76	3000
24410	M10x75	26	75	ø 40	8	M10	15	101	3000
24412	M10x100	26	100	ø 40	8	M10	15	126	3000
24414	M10x125	26	125	ø 40	8	M10	15	151	3000
24416	M12x50	26	50	ø 40	10	M12	15	76	3000
24418	M12x75	26	75	ø 40	10	M12	15	101	3000
24420	M12x100	26	100	ø 40	10	M12	15	126	3000
24422	M12x125	26	125	ø 40	10	M12	15	151	3000
24424	M12x150	26	150	ø 40	10	M12	15	176	3000

\* Disponibile con gomma EPDM blu  
Available with EPDM blu rubber

Caratteristiche: BASE VULCANIZZATA Ø 50, STELO SNODATO 10°

Features: VULCANIZED BASE Ø 50, 10° ARTICULATED STEM

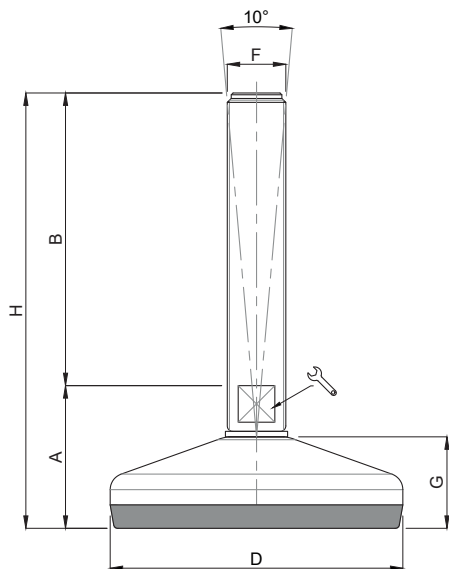

ESAGONO INTERNO IN TESTA  
TOP INTERNAL HEX

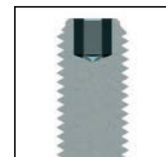



AGGIUNGI AL CODICE  
ADD TO CODE

CODICE - CODE	F	HEX
.../TIH5	M10	5
.../TIH6	M12	6
.../TIH8	M16	8
.../TIH10	M20/M24/M30	10

A richiesta - On request



CODICE CODE	DESCRIZIONE description	DIMENSIONI PRINCIPALI - MAIN DIMENSIONS							CARICO LOAD NEWTON	
		A	B	D			F	G		H
24500	M10x50	29	50	ø 50	-	14	M10	19	79	4000
24502	M10x75	29	75	ø 50	-	14	M10	19	104	4000
24504	M10x100	29	100	ø 50	-	14	M10	19	129	4000
24506	M10x125	29	125	ø 50	-	14	M10	19	154	4000
24507/BF	M10x150	32	150	ø 50	8	-	M10	19	182	4000
24508/BF	M10x175	32	175	ø 50	8	-	M10	19	207	4000
24509/BF	M10x200	32	200	ø 50	8	-	M10	19	232	4000
24600	M12x50	29	50	ø 50	-	14	M12	19	79	4000
24602	M12x75	29	75	ø 50	-	14	M12	19	104	4000
24604	M12x100	29	100	ø 50	-	14	M12	19	129	4000
24606	M12x125	29	125	ø 50	-	14	M12	19	154	4000
24607/BF	M12x150	32	150	ø 50	10	-	M12	19	182	4000
24608/BF	M12x175	32	175	ø 50	10	-	M12	19	207	4000
24609/BF	M12x200	32	200	ø 50	10	-	M12	19	232	4000
24700	M14x75	29	75	ø 50	-	14	M14	19	104	4000
24702	M14x100	29	100	ø 50	-	14	M14	19	129	4000
24704	M14x125	29	125	ø 50	-	14	M14	19	154	4000
24706	M14x150	29	150	ø 50	-	14	M14	19	179	4000
24708	M14x175	29	175	ø 50	-	14	M14	19	204	4000
24800	M16x75	32	75	ø 50	13	-	M16	19	107	4000
24802	M16x100	32	100	ø 50	13	-	M16	19	132	4000
24804	M16x125	32	125	ø 50	13	-	M16	19	157	4000
24806	M16x150	32	150	ø 50	13	-	M16	19	182	4000
24808	M16x175	32	175	ø 50	13	-	M16	19	207	4000
24810	M16x200	32	200	ø 50	13	-	M16	19	232	4000

\* Disponibile con gomma EPDM blu  
Available with EPDM blu rubber

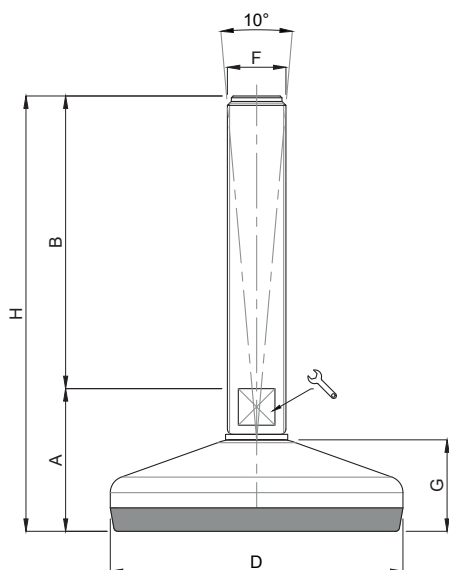

ESAGONO INTERNO IN TESTA  
TOP INTERNAL HEX

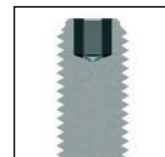



AGGIUNGI AL CODICE  
ADD TO CODE

CODICE - CODE	F	HEX
.../TIH5	M10	5
.../TIH6	M12	6
.../TIH8	M16	8
.../TIH10	M20/M24/M30	10

A richiesta - On request



CODICE CODE	DESCRIZIONE description	DIMENSIONI PRINCIPALI - MAIN DIMENSIONS								CARICO LOAD NEWTON
		A	B	D			F	G	H	
24510	M10x50	32	50	ø 60	-	14	M10	22	82	7000
24512	M10x75	32	75	ø 60	-	14	M10	22	107	7000
24514	M10x100	32	100	ø 60	-	14	M10	22	132	7000
24516	M10x125	32	125	ø 60	-	14	M10	22	157	7000
24518/BF	M10x150	35	150	ø 60	8	-	M10	22	185	7000
24520/BF	M10x175	35	175	ø 60	8	-	M10	22	210	7000
24522/BF	M10x200	35	200	ø 60	8	-	M10	22	235	7000
24610	M12x50	32	50	ø 60	-	14	M12	22	82	7000
24612	M12x75	32	75	ø 60	-	14	M12	22	107	7000
24614	M12x100	32	100	ø 60	-	14	M12	22	132	7000
24616	M12x125	32	125	ø 60	-	14	M12	22	157	7000
24618/BF	M12x150	35	150	ø 60	10	-	M12	22	185	7000
24620/BF	M12x175	35	175	ø 60	10	-	M12	22	210	7000
24622/BF	M12x200	35	200	ø 60	10	-	M12	22	235	7000
24710	M14x75	32	75	ø 60	-	14	M14	22	107	7000
24712	M14x100	32	100	ø 60	-	14	M14	22	132	7000
24714	M14x125	32	125	ø 60	-	14	M14	22	157	7000
24716	M14x150	32	150	ø 60	-	14	M14	22	182	7000
24718	M14x175	32	175	ø 60	-	14	M14	22	207	7000
24814	M16x75	35	75	ø 60	13	-	M16	22	110	7000
24816	M16x100	35	100	ø 60	13	-	M16	22	135	7000
24818	M16x125	35	125	ø 60	13	-	M16	22	160	7000
24820	M16x150	35	150	ø 60	13	-	M16	22	185	7000
24822	M16x175	35	175	ø 60	13	-	M16	22	210	7000
24824	M16x200	35	200	ø 60	13	-	M16	22	235	7000
24910	M20x75	35	75	ø 60	17	-	M20	22	110	7000
24912	M20x100	35	100	ø 60	17	-	M20	22	135	7000
24914	M20x125	35	125	ø 60	17	-	M20	22	160	7000
24916	M20x150	35	150	ø 60	17	-	M20	22	185	7000
24918	M20x175	35	175	ø 60	17	-	M20	22	210	7000
24920	M20x200	35	200	ø 60	17	-	M20	22	235	7000
24922	M20x225	35	225	ø 60	17	-	M20	22	260	7000
24924	M20x250	35	250	ø 60	17	-	M20	22	285	7000

\* Disponibile con gomma EPDM blu  
Available with EPDM blu rubber

Caratteristiche: BASE VULCANIZZATA Ø 80, STELO SNODATO 10°

Features: VULCANIZED BASE Ø 80, 10° ARTICULATED STEM

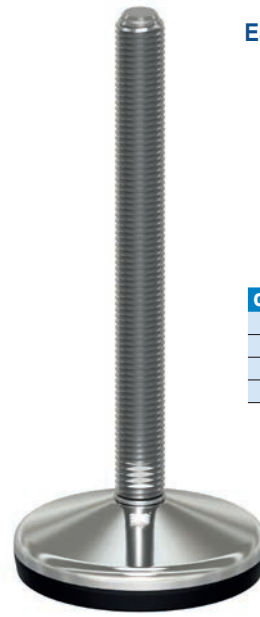
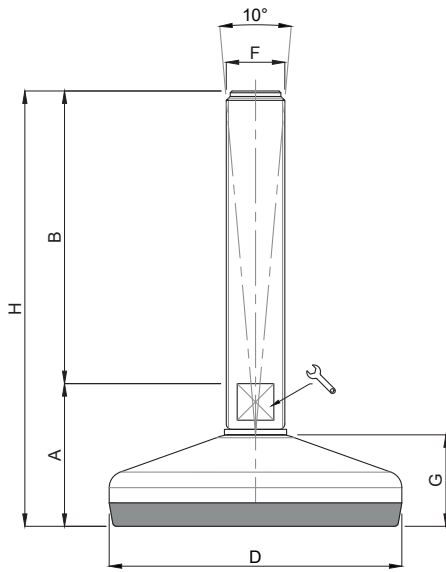

ESAGONO INTERNO IN TESTA  
TOP INTERNAL HEX

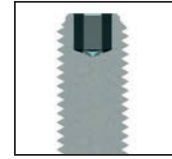

AGGIUNGI AL CODICE  
ADD TO CODE

CODICE - CODE	F	HEX
.../TIH5	M10	5
.../TIH6	M12	6
.../TIH8	M16	8
.../TIH10	M20/M24/M30	10

A richiesta - On request



CODICE CODE	DESCRIZIONE description	DIMENSIONI PRINCIPALI - MAIN DIMENSIONS								CARICO LOAD NEWTON
		A	B	D			F	G	H	
24900/10	M10x50	35	50	ø 80	-	14	M10	25	85	10000
25000/10	M10x75	35	75	ø 80	-	14	M10	25	110	10000
25002/10	M10x100	35	100	ø 80	-	14	M10	25	135	10000
25004/10	M10x125	35	125	ø 80	-	14	M10	25	160	10000
25006/10/BF	M10x150	38	150	ø 80	8	-	M10	25	188	10000
25008/10/BF	M10x175	38	175	ø 80	8	-	M10	25	213	10000
25010/10/BF	M10x200	38	200	ø 80	8	-	M10	25	238	10000
24900/12	M12x50	35	50	ø 80	-	14	M12	25	85	10000
25000/12	M12x75	35	75	ø 80	-	14	M12	25	110	10000
25002/12	M12x100	35	100	ø 80	-	14	M12	25	135	10000
25004/12	M12x125	35	125	ø 80	-	14	M12	25	160	10000
25006/12/BF	M12x150	38	150	ø 80	10	-	M12	25	188	10000
25008/12/BF	M12x175	38	175	ø 80	10	-	M12	25	213	10000
25010/12/BF	M12x200	38	200	ø 80	10	-	M12	25	238	10000
25000	M14x75	35	75	ø 80	-	14	M14	25	110	10000
25002	M14x100	35	100	ø 80	-	14	M14	25	135	10000
25004	M14x125	35	125	ø 80	-	14	M14	25	160	10000
25006	M14x150	35	150	ø 80	-	14	M14	25	185	10000
25008	M14x175	35	175	ø 80	-	14	M14	25	210	10000
25020	M16x75	35	75	ø 80	13	-	M16	25	110	10000
25022	M16x100	38	100	ø 80	13	-	M16	25	138	10000
25024	M16x125	38	125	ø 80	13	-	M16	25	163	10000
25026	M16x150	38	150	ø 80	13	-	M16	25	188	10000
25028	M16x175	38	175	ø 80	13	-	M16	25	213	10000
25030	M16x200	38	200	ø 80	13	-	M16	25	238	10000
25040	M20x75	38	75	ø 80	17	-	M20	25	113	10000
25042	M20x100	38	100	ø 80	17	-	M20	25	138	10000
25044	M20x125	38	125	ø 80	17	-	M20	25	163	10000
25046	M20x150	38	150	ø 80	17	-	M20	25	188	10000
25048	M20x175	38	175	ø 80	17	-	M20	25	213	10000
25050	M20x200	38	200	ø 80	17	-	M20	25	238	10000
25052	M20x225	38	225	ø 80	17	-	M20	25	263	10000
25054	M20x250	38	250	ø 80	17	-	M20	25	288	10000
25070	M24x75	40	75	ø 80	20	-	M24	25	115	10000
25072	M24x100	40	100	ø 80	20	-	M24	25	140	10000
25074	M24x125	40	125	ø 80	20	-	M24	25	165	10000
* 25076	M24x150	40	150	ø 80	20	-	M24	25	190	10000
* 25078	M24x175	40	175	ø 80	20	-	M24	25	215	10000
* 25080	M24x200	40	200	ø 80	20	-	M24	25	240	10000
25082	M24x225	40	225	ø 80	20	-	M24	25	265	10000
25084	M24x250	40	250	ø 80	20	-	M24	25	290	10000

\* Disponibile con Filettatura a passo fine. Aggiungere "/P2" al codice  
Available with Thin pitch thread. Please, add "/P2" to the code.

\* Disponibile con gomma EPDM blu  
Available with EPDM blue rubber

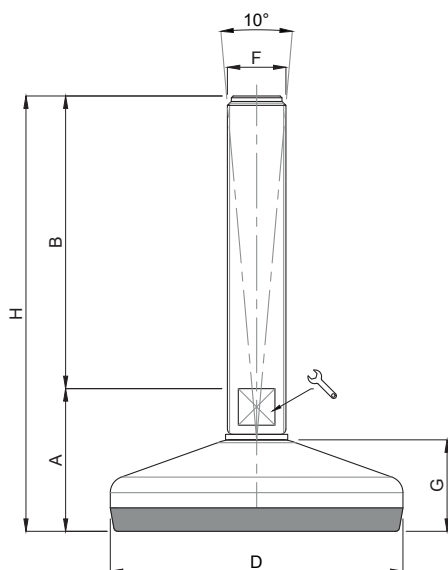

ESAGONO INTERNO IN TESTA  
TOP INTERNAL HEX

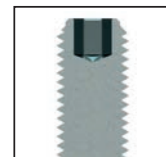

AGGIUNGI AL CODICE  
ADD TO CODE

CODICE - CODE	F	HEX
.../TIH5	M10	5
.../TIH6	M12	6
.../TIH8	M16	8
.../TIH10	M20/M24/M30	10

A richiesta - On request



CODICE CODE	DESCRIZIONE description	DIMENSIONI PRINCIPALI - MAIN DIMENSIONS							CARICO LOAD NEWTON	
		A	B	D			F	G		H
25100	M16x75	42	75	Ø 100	13	-	M16	28	117	15000
25102	M16x100	42	100	Ø 100	13	-	M16	28	142	15000
25104	M16x125	42	125	Ø 100	13	-	M16	28	167	15000
25106	M16x150	42	150	Ø 100	13	-	M16	28	192	15000
25108	M16x175	42	175	Ø 100	13	-	M16	28	217	15000
25110	M16x200	42	200	Ø 100	13	-	M16	28	242	15000
25120	M20x75	42	75	Ø 100	17	-	M20	28	117	15000
25122	M20x100	42	100	Ø 100	17	-	M20	28	142	15000
25124	M20x125	42	125	Ø 100	17	-	M20	28	167	15000
25126	M20x150	42	150	Ø 100	17	-	M20	28	192	15000
25128	M20x175	42	175	Ø 100	17	-	M20	28	217	15000
25130	M20x200	42	200	Ø 100	17	-	M20	28	242	15000
25132	M20x225	42	225	Ø 100	17	-	M20	28	267	15000
25134	M20x250	42	250	Ø 100	17	-	M20	28	292	15000
25150	M24x100	44	100	Ø 100	20	-	M24	28	144	15000
25152	M24x125	44	125	Ø 100	20	-	M24	28	169	15000
* 25154	M24x150	44	150	Ø 100	20	-	M24	28	194	15000
* 25156	M24x175	44	175	Ø 100	20	-	M24	28	219	15000
* 25158	M24x200	44	200	Ø 100	20	-	M24	28	244	15000
25160	M24x225	44	225	Ø 100	20	-	M24	28	269	15000
25162	M24x250	44	250	Ø 100	20	-	M24	28	294	15000
25180	M30x100	44	100	Ø 100	-	26	M30	28	144	15000
25182	M30x125	44	125	Ø 100	-	26	M30	28	169	15000
* 25184	M30x150	44	150	Ø 100	-	26	M30	28	194	15000
25186	M30x175	44	175	Ø 100	-	26	M30	28	219	15000
* 25188	M30x200	44	200	Ø 100	-	26	M30	28	244	15000
25200	M30x225	44	225	Ø 100	-	26	M30	28	269	15000
25202	M30x250	44	250	Ø 100	-	26	M30	28	294	15000

\* Disponibile con Filettatura a passo fine. Aggiungere "/P2" al codice  
Available with Thin pitch thread. Please, add "/P2" to the code.

\* Disponibile con gomma EPDM blu  
Available with EPDM blu rubber

Caratteristiche: BASE VULCANIZZATA Ø 120, STELO SNODATO 10°

Features: VULCANIZED BASE Ø 120, 10° ARTICULATED STEM

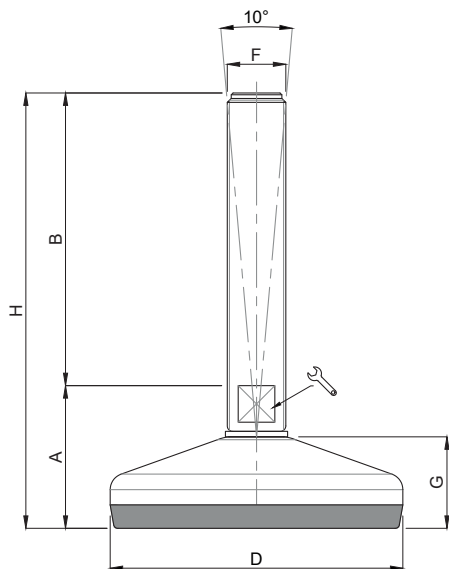

ESAGONO INTERNO IN TESTA  
TOP INTERNAL HEX

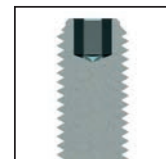

AGGIUNGI AL CODICE  
ADD TO CODE

CODICE - CODE	F	HEX
.../TIH5	M10	5
.../TIH6	M12	6
.../TIH8	M16	8
.../TIH10	M20/M24/M30	10

A richiesta - On request



CODICE CODE	DESCRIZIONE description	DIMENSIONI PRINCIPALI - MAIN DIMENSIONS							CARICO LOAD NEWTON	
		A	B	D			F	G		H
25250	M16x75	47	75	Ø 120	13	-	M16	32	122	30000
25252	M16x100	47	100	Ø 120	13	-	M16	32	147	30000
25254	M16x125	47	125	Ø 120	13	-	M16	32	172	30000
25256	M16x150	47	150	Ø 120	13	-	M16	32	197	30000
25258	M16x175	47	175	Ø 120	13	-	M16	32	222	30000
25260	M16x200	47	200	Ø 120	13	-	M16	32	247	30000
25262	M20x75	47	75	Ø 120	17	-	M20	32	122	30000
25264	M20x100	47	100	Ø 120	17	-	M20	32	147	30000
25266	M20x125	47	125	Ø 120	17	-	M20	32	172	30000
25268	M20x150	47	150	Ø 120	17	-	M20	32	197	30000
25270	M20x175	47	175	Ø 120	17	-	M20	32	222	30000
25272	M20x200	47	200	Ø 120	17	-	M20	32	247	30000
25274	M20x225	47	225	Ø 120	17	-	M20	32	272	30000
25276	M20x250	47	250	Ø 120	17	-	M20	32	297	30000
25278	M24x100	49	100	Ø 120	20	-	M24	32	149	30000
25280	M24x125	49	125	Ø 120	20	-	M24	32	174	30000
* 25282	M24x150	49	150	Ø 120	20	-	M24	32	199	30000
* 25284	M24x175	49	175	Ø 120	20	-	M24	32	224	30000
* 25286	M24x200	49	200	Ø 120	20	-	M24	32	249	30000
25288	M24x225	49	225	Ø 120	20	-	M24	32	274	30000
25290	M24x250	49	250	Ø 120	20	-	M24	32	299	30000
25292	M30x100	49	100	Ø 120	-	26	M30	32	149	30000
25294	M30x125	49	125	Ø 120	-	26	M30	32	174	30000
* 25296	M30x150	49	150	Ø 120	-	26	M30	32	199	30000
25298	M30x175	49	175	Ø 120	-	26	M30	32	224	30000
* 25300	M30x200	49	200	Ø 120	-	26	M30	32	249	30000
25302	M30x225	49	225	Ø 120	-	26	M30	32	274	30000
25304	M30x250	49	250	Ø 120	-	26	M30	32	299	30000

\* Disponibile con Filettatura a passo fine. Aggiungere "/P2" al codice  
Available with Thin pitch thread. Please, add "/P2" to the code.

\* Disponibile con gomma EPDM blu  
Available with EPDM blu rubber

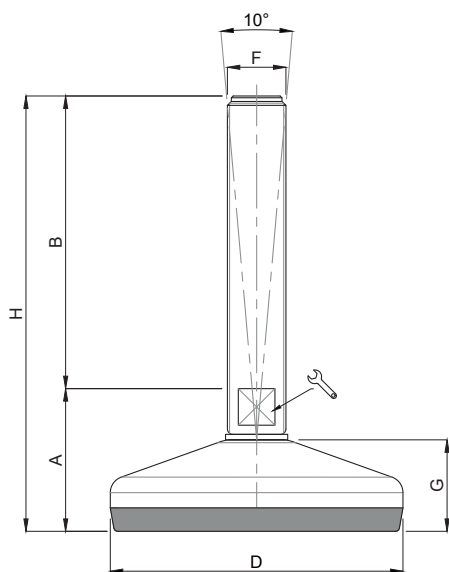

ESAGONO INTERNO IN TESTA  
TOP INTERNAL HEX

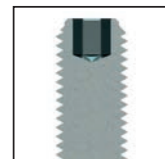

AGGIUNGI AL CODICE  
ADD TO CODE

CODICE - CODE	F	HEX
.../TIH5	M10	5
.../TIH6	M12	6
.../TIH8	M16	8
.../TIH10	M20/M24/M30	10

A richiesta - On request



CODICE CODE	DESCRIZIONE description	DIMENSIONI PRINCIPALI - MAIN DIMENSIONS								CARICO LOAD NEWTON
		A	B	D			F	G	H	
25306	M16x75	49	75	Ø 150	13	-	M16	35	124	30000
25308	M16x100	49	100	Ø 150	13	-	M16	35	149	30000
25310	M16x125	49	125	Ø 150	13	-	M16	35	174	30000
25312	M16x150	49	150	Ø 150	13	-	M16	35	199	30000
25314	M16x175	49	175	Ø 150	13	-	M16	35	224	30000
25316	M16x200	49	200	Ø 150	13	-	M16	35	249	30000
25318	M20x75	48	75	Ø 150	17	-	M20	35	123	30000
25320	M20x100	48	100	Ø 150	17	-	M20	35	148	30000
25322	M20x125	48	125	Ø 150	17	-	M20	35	173	30000
25324	M20x150	48	150	Ø 150	17	-	M20	35	198	30000
25326	M20x175	48	175	Ø 150	17	-	M20	35	223	30000
25328	M20x200	48	200	Ø 150	17	-	M20	35	248	30000
25330	M20x225	48	225	Ø 150	17	-	M20	35	273	30000
25332	M20x250	48	250	Ø 150	17	-	M20	35	298	30000
25334	M24x100	49	100	Ø 150	20	-	M24	35	149	40000
25336	M24x125	49	125	Ø 150	20	-	M24	35	174	40000
* 25338	M24x150	49	150	Ø 150	20	-	M24	35	199	40000
* 25340	M24x175	49	175	Ø 150	20	-	M24	35	224	40000
* 25342	M24x200	49	200	Ø 150	20	-	M24	35	249	40000
25344	M24x225	49	225	Ø 150	20	-	M24	35	274	40000
25346	M24x250	49	250	Ø 150	20	-	M24	35	299	40000
25348	M30x100	50	100	Ø 150	-	26	M30	35	150	40000
25350	M30x125	50	125	Ø 150	-	26	M30	35	175	40000
* 25352	M30x150	50	150	Ø 150	-	26	M30	35	200	40000
25354	M30x175	50	175	Ø 150	-	26	M30	35	225	40000
* 25356	M30x200	50	200	Ø 150	-	26	M30	35	250	40000
25358	M30x225	50	225	Ø 150	-	26	M30	35	275	40000
25360	M30x250	50	250	Ø 150	-	26	M30	35	300	40000
25362	M36x150	50	150	Ø 150	-	32	M36	35	200	40000
25364	M36x200	50	200	Ø 150	-	32	M36	35	250	40000
25366	M36x250	50	250	Ø 150	-	32	M36	35	300	40000

\* Disponibile con Filettatura a passo fine. Aggiungere "/P2" al codice  
Available with Thin pitch thread. Please, add "/P2" to the code.

\* Disponibile con gomma EPDM blu  
Available with EPDM blu rubber

# Piede Inox

# VULCANIZZATO



Caratteristiche: BASE VULCANIZZATA Ø 60 CON FISSAGGIO, STELO SNODATO 10°

Features: VULCANIZED BOLT/DOWN BASE Ø 60, 10° ARTICULATED STEM

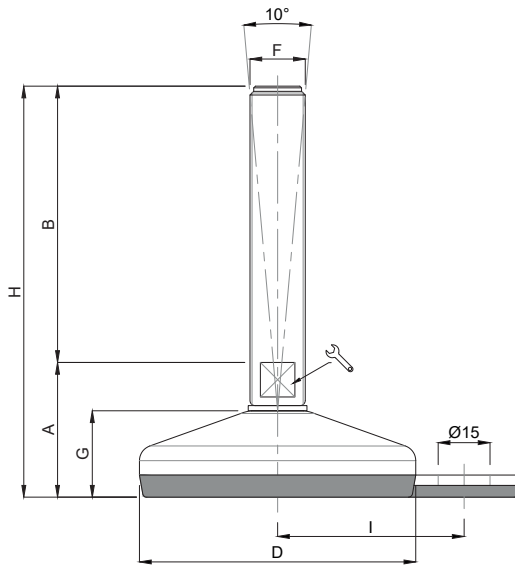

ESAGONO INTERNO IN TESTA  
TOP INTERNAL HEX

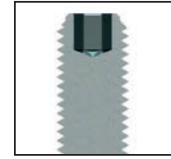

AGGIUNGI AL CODICE  
ADD TO CODE

CODICE - CODE	F	HEX
.../TIH5	M10	5
.../TIH6	M12	6
.../TIH8	M16	8
.../TIH10	M20/M24/M30	10

A richiesta - On request

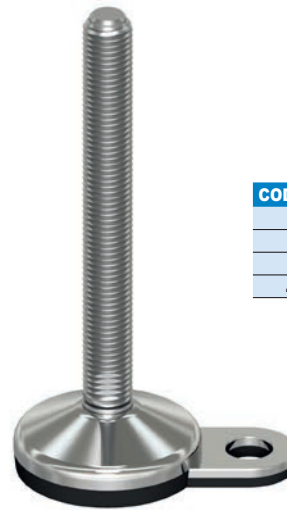

CODICE CODE	DESCRIZIONE description	DIMENSIONI PRINCIPALI - MAIN DIMENSIONS									CARICO LOAD NEWTON
		A	B	D			F	G	H	I	
24510/F	M10x50	32	50	ø 60	-	14	M10	22	82	45	7000
24512/F	M10x75	32	75	ø 60	-	14	M10	22	107	45	7000
24514/F	M10x100	32	100	ø 60	-	14	M10	22	132	45	7000
24516/F	M10x125	32	125	ø 60	-	14	M10	22	157	45	7000
24518/BF/F	M10x150	35	150	ø 60	8	-	M10	22	185	45	7000
24520/BF/F	M10x175	35	175	ø 60	8	-	M10	22	210	45	7000
24522/BF/F	M10x200	35	200	ø 60	8	-	M10	22	235	45	7000
24610/F	M12x50	32	50	ø 60	-	14	M12	22	82	45	7000
24612/F	M12x75	32	75	ø 60	-	14	M12	22	107	45	7000
24614/F	M12x100	32	100	ø 60	-	14	M12	22	132	45	7000
24616/F	M12x125	32	125	ø 60	-	14	M12	22	157	45	7000
24618/BF/F	M12x150	35	150	ø 60	10	-	M12	22	185	45	7000
24620/BF/F	M12x175	35	175	ø 60	10	-	M12	22	210	45	7000
24622/BF/F	M12x200	35	200	ø 60	10	-	M12	22	235	45	7000
24710/F	M14x75	32	75	ø 60	-	14	M14	22	107	45	7000
24712/F	M14x100	32	100	ø 60	-	14	M14	22	132	45	7000
24714/F	M14x125	32	125	ø 60	-	14	M14	22	157	45	7000
24716/F	M14x150	32	150	ø 60	-	14	M14	22	182	45	7000
24718/F	M14x175	32	175	ø 60	-	14	M14	22	207	45	7000
24814/F	M16x75	35	75	ø 60	13	-	M16	22	110	45	7000
24816/F	M16x100	35	100	ø 60	13	-	M16	22	135	45	7000
24818/F	M16x125	35	125	ø 60	13	-	M16	22	160	45	7000
24820/F	M16x150	35	150	ø 60	13	-	M16	22	185	45	7000
24822/F	M16x175	35	175	ø 60	13	-	M16	22	210	45	7000
24824/F	M16x200	35	200	ø 60	13	-	M16	22	235	45	7000
24910/F	M20x75	35	75	ø 60	17	-	M20	22	110	45	7000
24912/F	M20x100	35	100	ø 60	17	-	M20	22	135	45	7000
24914/F	M20x125	35	125	ø 60	17	-	M20	22	160	45	7000
24916/F	M20x150	35	150	ø 60	17	-	M20	22	185	45	7000
24918/F	M20x175	35	175	ø 60	17	-	M20	22	210	45	7000
24920/F	M20x200	35	200	ø 60	17	-	M20	22	235	45	7000
24922/F	M20x225	35	225	ø 60	17	-	M20	22	260	45	7000
24924/F	M20x250	35	250	ø 60	17	-	M20	22	285	45	7000

\* Disponibile con gomma EPDM blu  
Available with EPDM blu rubber

Caratteristiche: BASE VULCANIZZATA Ø 60 CON DOPPIO FISSAGGIO, STELO SNODATO 10°

Features: VULCANIZED BOLT/DOWN BASE Ø 60, 10° ARTICULATED STEM

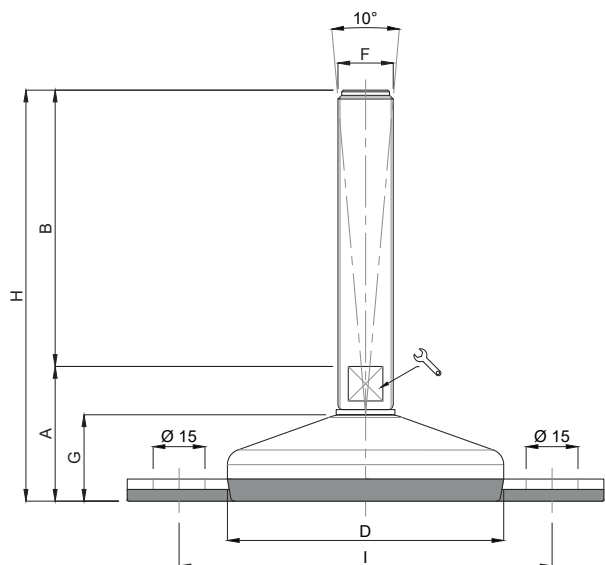

ESAGONO INTERNO IN TESTA  
TOP INTERNAL HEX

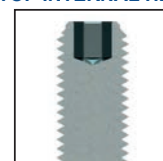

CODICE - CODE	F	HEX
.../TIH5	M10	5
.../TIH6	M12	6
.../TIH8	M16	8
.../TIH10	M20/M24/M30	10



CODICE CODE	DESCRIZIONE description	DIMENSIONI PRINCIPALI - MAIN DIMENSIONS									CARICO LOAD NEWTON
		A	B	D			F	G	H	I	
24510/FF	M10x50	32	50	Ø 60	-	14	M10	22	82	90	7000
24512/FF	M10x75	32	75	Ø 60	-	14	M10	22	107	90	7000
24514/FF	M10x100	32	100	Ø 60	-	14	M10	22	132	90	7000
24516/FF	M10x125	32	125	Ø 60	-	14	M10	22	157	90	7000
24518/BF/FF	M10x150	35	150	Ø 60	8	-	M10	22	185	90	7000
24520/BF/FF	M10x175	35	175	Ø 60	8	-	M10	22	210	90	7000
24522/BF/FF	M10x200	35	200	Ø 60	8	-	M10	22	235	90	7000
24610/FF	M12x50	32	50	Ø 60	-	14	M12	22	82	90	7000
24612/FF	M12x75	32	75	Ø 60	-	14	M12	22	107	90	7000
24614/FF	M12x100	32	100	Ø 60	-	14	M12	22	132	90	7000
24616/FF	M12x125	32	125	Ø 60	-	14	M12	22	157	90	7000
24618/BF/FF	M12x150	35	150	Ø 60	10	-	M12	22	185	90	7000
24620/BF/FF	M12x175	35	175	Ø 60	10	-	M12	22	210	90	7000
24622/BF/FF	M12x200	35	200	Ø 60	10	-	M12	22	235	90	7000
24710/FF	M14x75	32	75	Ø 60	-	14	M14	22	107	90	7000
24712/FF	M14x100	32	100	Ø 60	-	14	M14	22	132	90	7000
24714/FF	M14x125	32	125	Ø 60	-	14	M14	22	157	90	7000
24716/FF	M14x150	32	150	Ø 60	-	14	M14	22	182	90	7000
24718/FF	M14x175	32	175	Ø 60	-	14	M14	22	207	90	7000
24814/FF	M16x75	35	75	Ø 60	13	-	M16	22	110	90	7000
24816/FF	M16x100	35	100	Ø 60	13	-	M16	22	135	90	7000
24818/FF	M16x125	35	125	Ø 60	13	-	M16	22	160	90	7000
24820/FF	M16x150	35	150	Ø 60	13	-	M16	22	185	90	7000
24822/FF	M16x175	35	175	Ø 60	13	-	M16	22	210	90	7000
24824/FF	M16x200	35	200	Ø 60	13	-	M16	22	235	90	7000
24910/FF	M20x75	35	75	Ø 60	17	-	M20	22	110	90	7000
24912/FF	M20x100	35	100	Ø 60	17	-	M20	22	135	90	7000
24914/FF	M20x125	35	125	Ø 60	17	-	M20	22	160	90	7000
24916/FF	M20x150	35	150	Ø 60	17	-	M20	22	185	90	7000
24918/FF	M20x175	35	175	Ø 60	17	-	M20	22	210	90	7000
24920/FF	M20x200	35	200	Ø 60	17	-	M20	22	235	90	7000
24922/FF	M20x225	35	225	Ø 60	17	-	M20	22	260	90	7000
24924/FF	M20x250	35	250	Ø 60	17	-	M20	22	285	90	7000

\* Disponibile con gomma EPDM blu  
Available with EPDM blue rubber

# Piede Inox

# VULCANIZZATO



Caratteristiche: BASE VULCANIZZATA Ø 80 CON FISSAGGIO, STELO SNODATO 10°

Features: VULCANIZED BOLT/DOWN BASE Ø 80, 10° ARTICULATED STEM

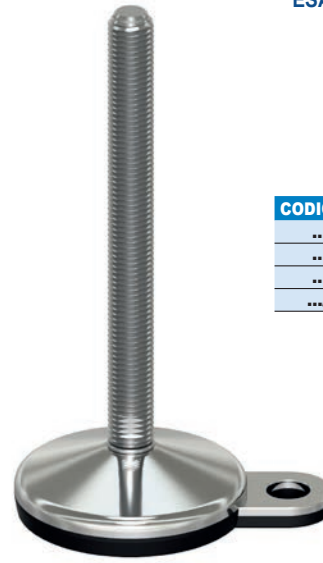
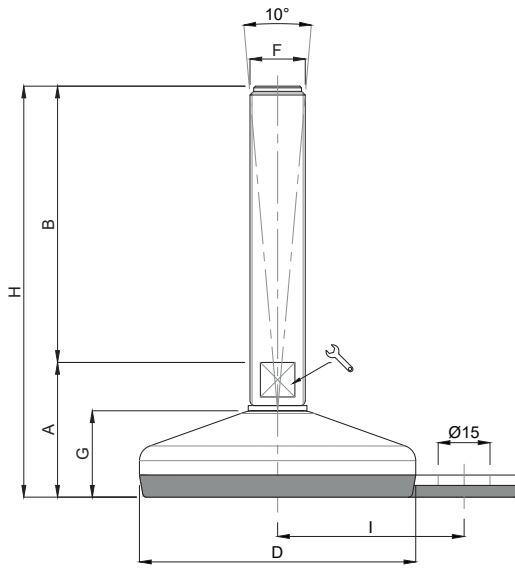

ESAGONO INTERNO IN TESTA  
TOP INTERNAL HEX

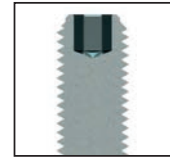

CODICE - CODE	F	HEX
.../TIH5	M10	5
.../TIH6	M12	6
.../TIH8	M16	8
.../TIH10	M20/M24/M30	10



CODICE CODE	DESCRIZIONE description	DIMENSIONI PRINCIPALI - MAIN DIMENSIONS										CARICO LOAD NEWTON
		A	B	D			F	G	H	I		
24900/10/F	M10x50	35	50	Ø 80	-	14	M10	25	85	54	10000	
25000/10/F	M10x75	35	75	Ø 80	-	14	M10	25	110	54	10000	
25002/10/F	M10x100	35	100	Ø 80	-	14	M10	25	135	54	10000	
25004/10/F	M10x125	35	125	Ø 80	-	14	M10	25	160	54	10000	
25006/10/BF/F	M10x150	38	150	Ø 80	8	-	M10	25	188	54	10000	
25008/10/BF/F	M10x175	38	175	Ø 80	8	-	M10	25	213	54	10000	
25010/10/BF/F	M10x200	38	200	Ø 80	8	-	M10	25	238	54	10000	
24900/12/F	M12x50	35	50	Ø 80	-	14	M12	25	85	54	10000	
25000/12/F	M12x75	35	75	Ø 80	-	14	M12	25	110	54	10000	
25002/12/F	M12x100	35	100	Ø 80	-	14	M12	25	135	54	10000	
25004/12/F	M12x125	35	125	Ø 80	-	14	M12	25	160	54	10000	
25006/12/BF/F	M12x150	38	150	Ø 80	10	-	M12	25	188	54	10000	
25008/12/BF/F	M12x175	38	175	Ø 80	10	-	M12	25	213	54	10000	
25010/12/BF/F	M12x200	38	200	Ø 80	10	-	M12	25	238	54	10000	
25000/F	M14x75	35	75	Ø 80	-	14	M14	25	110	54	10000	
25002/F	M14x100	35	100	Ø 80	-	14	M14	25	135	54	10000	
25004/F	M14x125	35	125	Ø 80	-	14	M14	25	160	54	10000	
25006/F	M14x150	35	150	Ø 80	-	14	M14	25	185	54	10000	
25008/F	M14x175	35	175	Ø 80	-	14	M14	25	210	54	10000	
25020/F	M16x75	35	75	Ø 80	13	-	M16	25	110	54	10000	
25022/F	M16x100	38	100	Ø 80	13	-	M16	25	138	54	10000	
25024/F	M16x125	38	125	Ø 80	13	-	M16	25	163	54	10000	
25026/F	M16x150	38	150	Ø 80	13	-	M16	25	188	54	10000	
25028/F	M16x175	38	175	Ø 80	13	-	M16	25	213	54	10000	
25030/F	M16x200	38	200	Ø 80	13	-	M16	25	238	54	10000	
25040/F	M20x75	38	75	Ø 80	17	-	M20	25	113	54	10000	
25042/F	M20x100	38	100	Ø 80	17	-	M20	25	138	54	10000	
25044/F	M20x125	38	125	Ø 80	17	-	M20	25	163	54	10000	
25046/F	M20x150	38	150	Ø 80	17	-	M20	25	188	54	10000	
25048/F	M20x175	38	175	Ø 80	17	-	M20	25	213	54	10000	
25050/F	M20x200	38	200	Ø 80	17	-	M20	25	238	54	10000	
25052/F	M20x225	38	225	Ø 80	17	-	M20	25	263	54	10000	
25054/F	M20x250	38	250	Ø 80	17	-	M20	25	288	54	10000	
25070/F	M24x75	40	75	Ø 80	20	-	M24	25	115	54	10000	
25072/F	M24x100	40	100	Ø 80	20	-	M24	25	140	54	10000	
25074/F	M24x125	40	125	Ø 80	20	-	M24	25	165	54	10000	
* 25076/F	M24x150	40	150	Ø 80	20	-	M24	25	190	54	10000	
* 25078/F	M24x175	40	175	Ø 80	20	-	M24	25	215	54	10000	
* 25080/F	M24x200	40	200	Ø 80	20	-	M24	25	240	54	10000	
* 25082/F	M24x225	40	225	Ø 80	20	-	M24	25	265	54	10000	
* 25084/F	M24x250	40	250	Ø 80	20	-	M24	25	290	54	10000	

\* Disponibile con Filettatura a passo fine. Aggiungere "/P2" al codice  
Available with Thin pitch thread. Please, add "/P2" to the code.

\* Disponibile con gomma EPDM blu  
Available with EPDM blu rubber

Caratteristiche: BASE VULCANIZZATA Ø 80 CON DOPPIO FISSAGGIO, STELO SNODATO 10°

Features: VULCANIZED BOLT/DOWN BASE Ø 80, 10° ARTICULATED STEM

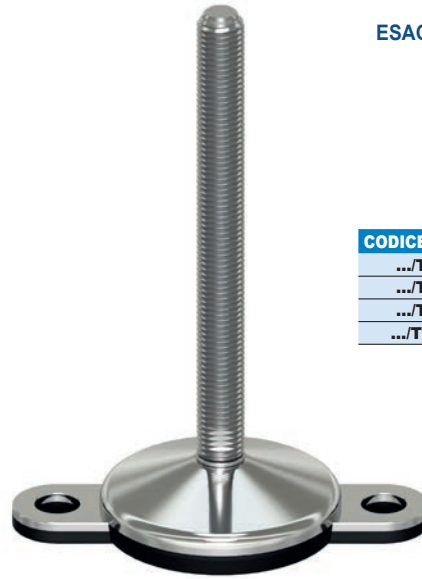
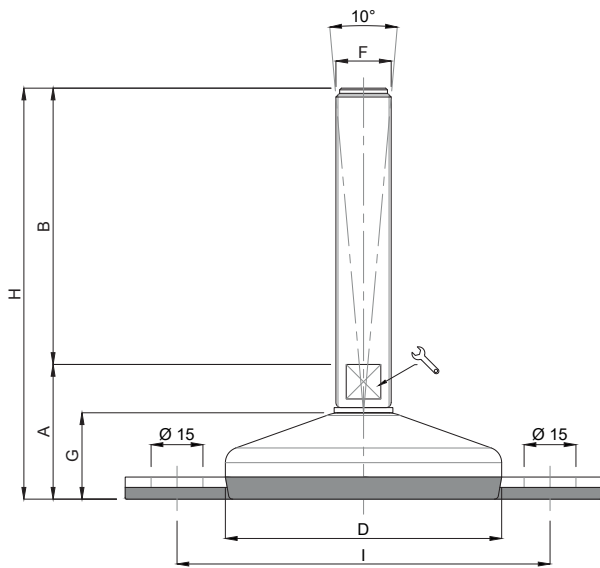

ESAGONO INTERNO IN TESTA  
TOP INTERNAL HEX

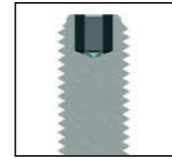

CODICE - CODE	F	HEX
.../TIH5	M10	5
.../TIH6	M12	6
.../TIH8	M16	8
.../TIH10	M20/M24/M30	10



CODICE CODE	DESCRIZIONE description	DIMENSIONI PRINCIPALI - MAIN DIMENSIONS									CARICO LOAD NEWTON
		A	B	D			F	G	H	I	
24900/10/FF	M10x50	35	50	ø 80	-	14	M10	25	85	108	10000
25000/10/FF	M10x75	35	75	ø 80	-	14	M10	25	110	108	10000
25002/10/FF	M10x100	35	100	ø 80	-	14	M10	25	135	108	10000
25004/10/FF	M10x125	35	125	ø 80	-	14	M10	25	160	108	10000
25006/10/BF/FF	M10x150	38	150	ø 80	8	-	M10	25	188	108	10000
25008/10/BF/FF	M10x175	38	175	ø 80	8	-	M10	25	213	108	10000
25010/10/BF/FF	M10x200	38	200	ø 80	8	-	M10	25	238	108	10000
24900/12/FF	M12x50	35	50	ø 80	-	14	M12	25	85	108	10000
25000/12/FF	M12x75	35	75	ø 80	-	14	M12	25	110	108	10000
25002/12/FF	M12x100	35	100	ø 80	-	14	M12	25	135	108	10000
25004/12/FF	M12x125	35	125	ø 80	-	14	M12	25	160	108	10000
25006/12/BF/FF	M12x150	38	150	ø 80	10	-	M12	25	188	108	10000
25008/12/BF/FF	M12x175	38	175	ø 80	10	-	M12	25	213	108	10000
25010/12/BF/FF	M12x200	38	200	ø 80	10	-	M12	25	238	108	10000
25000/FF	M14x75	35	75	ø 80	-	14	M14	25	110	108	10000
25002/FF	M14x100	35	100	ø 80	-	14	M14	25	135	108	10000
25004/FF	M14x125	35	125	ø 80	-	14	M14	25	160	108	10000
25006/FF	M14x150	35	150	ø 80	-	14	M14	25	185	108	10000
25008/FF	M14x175	35	175	ø 80	-	14	M14	25	210	108	10000
25020/FF	M16x75	35	75	ø 80	13	-	M16	25	110	108	10000
25022/FF	M16x100	38	100	ø 80	13	-	M16	25	138	108	10000
25024/FF	M16x125	38	125	ø 80	13	-	M16	25	163	108	10000
25026/FF	M16x150	38	150	ø 80	13	-	M16	25	188	108	10000
25028/FF	M16x175	38	175	ø 80	13	-	M16	25	213	108	10000
25030/FF	M16x200	38	200	ø 80	13	-	M16	25	238	108	10000
25040/FF	M20x75	38	75	ø 80	17	-	M20	25	113	108	10000
25042/FF	M20x100	38	100	ø 80	17	-	M20	25	138	108	10000
25044/FF	M20x125	38	125	ø 80	17	-	M20	25	163	108	10000
25046/FF	M20x150	38	150	ø 80	17	-	M20	25	188	108	10000
25048/FF	M20x175	38	175	ø 80	17	-	M20	25	213	108	10000
25050/FF	M20x200	38	200	ø 80	17	-	M20	25	238	108	10000
25052/FF	M20x225	38	225	ø 80	17	-	M20	25	263	108	10000
25054/FF	M20x250	38	250	ø 80	17	-	M20	25	288	108	10000
25070/FF	M24x75	40	75	ø 80	20	-	M24	25	115	108	10000
25072/FF	M24x100	40	100	ø 80	20	-	M24	25	140	108	10000
25074/FF	M24x125	40	125	ø 80	20	-	M24	25	165	108	10000
* 25076/FF	M24x150	40	150	ø 80	20	-	M24	25	190	108	10000
* 25078/FF	M24x175	40	175	ø 80	20	-	M24	25	215	108	10000
* 25080/FF	M24x200	40	200	ø 80	20	-	M24	25	240	108	10000
* 25082/FF	M24x225	40	225	ø 80	20	-	M24	25	265	108	10000
* 25084/FF	M24x250	40	250	ø 80	20	-	M24	25	290	108	10000

\* Disponibile con Filettatura a passo fine. Aggiungere "/P2" al codice  
Available with Thin pitch thread. Please, add "/P2" to the code.

\* Disponibile con gomma EPDM blu  
Available with EPDM blu rubber

# Piede Inox

# VULCANIZZATO

Caratteristiche: BASE VULCANIZZATA Ø 100 CON FISSAGGIO, STELO SNODATO 10°

Features: VULCANIZED BOLT/DOWN BASE Ø 100, 10° ARTICULATED STEM

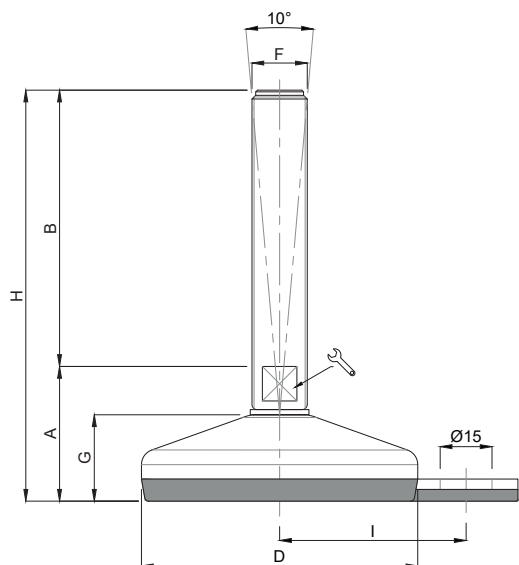

ESAGONO INTERNO IN TESTA  
TOP INTERNAL HEX

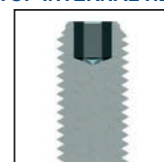

CODICE - CODE	F	HEX
.../TIH5	M10	5
.../TIH6	M12	6
.../TIH8	M16	8
.../TIH10	M20/M24/M30	10



CODICE CODE	DESCRIZIONE description	DIMENSIONI PRINCIPALI - MAIN DIMENSIONS									CARICO LOAD NEWTON
		A	B	D			F	G	H	I	
25100/F	M16x75	42	75	Ø 100	13	-	M16	28	117	69	15000
25102/F	M16x100	42	100	Ø 100	13	-	M16	28	142	69	15000
25104/F	M16x125	42	125	Ø 100	13	-	M16	28	167	69	15000
25106/F	M16x150	42	150	Ø 100	13	-	M16	28	192	69	15000
25108/F	M16x175	42	175	Ø 100	13	-	M16	28	217	69	15000
25110/F	M16x200	42	200	Ø 100	13	-	M16	28	242	69	15000
25120/F	M20x75	42	75	Ø 100	17	-	M20	28	117	69	15000
25122/F	M20x100	42	100	Ø 100	17	-	M20	28	142	69	15000
25124/F	M20x125	42	125	Ø 100	17	-	M20	28	167	69	15000
25126/F	M20x150	42	150	Ø 100	17	-	M20	28	192	69	15000
25128/F	M20x175	42	175	Ø 100	17	-	M20	28	217	69	15000
25130/F	M20x200	42	200	Ø 100	17	-	M20	28	242	69	15000
25132/F	M20x225	42	225	Ø 100	17	-	M20	28	267	69	15000
25134/F	M20x250	42	250	Ø 100	17	-	M20	28	292	69	15000
25150/F	M24x100	44	100	Ø 100	20	-	M24	28	144	69	15000
25152/F	M24x125	44	125	Ø 100	20	-	M24	28	169	69	15000
* 25154/F	M24x150	44	150	Ø 100	20	-	M24	28	194	69	15000
25156/F	M24x175	44	175	Ø 100	20	-	M24	28	219	69	15000
* 25158/F	M24x200	44	200	Ø 100	20	-	M24	28	244	69	15000
25160/F	M24x225	44	225	Ø 100	20	-	M24	28	269	69	15000
25162/F	M24x250	44	250	Ø 100	20	-	M24	28	294	69	15000
25180/F	M30x100	44	100	Ø 100	-	26	M30	28	144	69	15000
25182/F	M30x125	44	125	Ø 100	-	26	M30	28	169	69	15000
* 25184/F	M30x150	44	150	Ø 100	-	26	M30	28	194	69	15000
25186/F	M30x175	44	175	Ø 100	-	26	M30	28	219	69	15000
* 25188/F	M30x200	44	200	Ø 100	-	26	M30	28	244	69	15000
25200/F	M30x225	44	225	Ø 100	-	26	M30	28	269	69	15000
25202/F	M30x250	44	250	Ø 100	-	26	M30	28	294	69	15000

\* Disponibile con Filettatura a passo fine. Aggiungere "/P2" al codice  
Available with Thin pitch thread. Please, add "/P2" to the code.

\* Disponibile con gomma EPDM blu  
Available with EPDM blu rubber

Caratteristiche: BASE VULCANIZZATA Ø 120 CON FISSAGGIO,  
STELO SNODATO 10°

Features: VULCANIZED BOLT/DOWN BASE Ø 120,  
10° ARTICULATED STEM

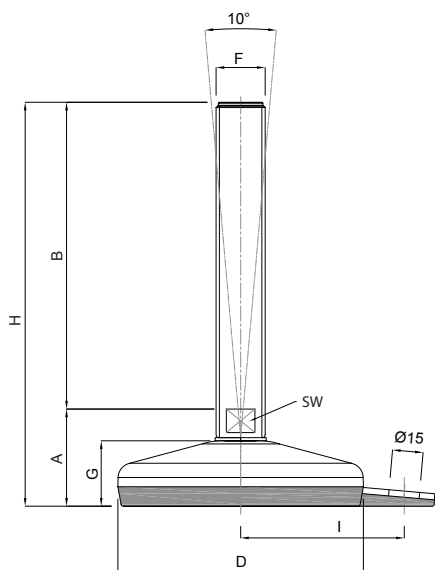

ESAGONO INTERNO IN TESTA  
TOP INTERNAL HEX

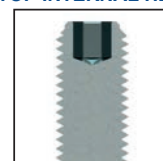

CODICE - CODE	F	HEX
.../TIH5	M10	5
.../TIH6	M12	6
.../TIH8	M16	8
.../TIH10	M20/M24/M30	10

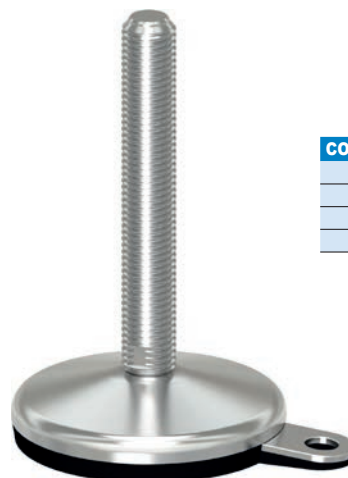

CODICE CODE	DESCRIZIONE description	DIMENSIONI PRINCIPALI - MAIN DIMENSIONS									CARICO LOAD NEWTON
		A	B	D			F	G	H	I	
25250/F	M16x75	47	75	Ø 120	13	-	M16	32	122	80	30000
25252/F	M16x100	47	100	Ø 120	13	-	M16	32	147	80	30000
25254/F	M16x125	47	125	Ø 120	13	-	M16	32	172	80	30000
25256/F	M16x150	47	150	Ø 120	13	-	M16	32	197	80	30000
25258/F	M16x175	47	175	Ø 120	13	-	M16	32	222	80	30000
25260/F	M16x200	47	200	Ø 120	13	-	M16	32	247	80	30000
25262/F	M20x75	47	75	Ø 120	17	-	M20	32	122	80	30000
25264/F	M20x100	47	100	Ø 120	17	-	M20	32	147	80	30000
25266/F	M20x125	47	125	Ø 120	17	-	M20	32	172	80	30000
25268/F	M20x150	47	150	Ø 120	17	-	M20	32	197	80	30000
25270/F	M20x175	47	175	Ø 120	17	-	M20	32	222	80	30000
25272/F	M20x200	47	200	Ø 120	17	-	M20	32	247	80	30000
25274/F	M20x225	47	225	Ø 120	17	-	M20	32	272	80	30000
25276/F	M20x250	47	250	Ø 120	17	-	M20	32	297	80	30000
25278/F	M24x100	49	100	Ø 120	20	-	M24	32	149	80	30000
25280/F	M24x125	49	125	Ø 120	20	-	M24	32	174	80	30000
* 25282/F	M24x150	49	150	Ø 120	20	-	M24	32	199	80	30000
* 25284/F	M24x175	49	175	Ø 120	20	-	M24	32	224	80	30000
* 25286/F	M24x200	49	200	Ø 120	20	-	M24	32	249	80	30000
25288/F	M24x225	49	225	Ø 120	20	-	M24	32	274	80	30000
25290/F	M24x250	49	250	Ø 120	20	-	M24	32	299	80	30000
25292/F	M30x100	49	100	Ø 120	-	26	M30	32	149	80	30000
25294/F	M30x125	49	125	Ø 120	-	26	M30	32	174	80	30000
* 25296/F	M30x150	49	150	Ø 120	-	26	M30	32	199	80	30000
25298/F	M30x175	49	175	Ø 120	-	26	M30	32	224	80	30000
* 25300/F	M30x200	49	200	Ø 120	-	26	M30	32	249	80	30000
25302/F	M30x225	49	225	Ø 120	-	26	M30	32	274	80	30000
25304/F	M30x250	49	250	Ø 120	-	26	M30	32	299	80	30000

\* Disponibile con Filettatura a passo fine. Aggiungere "/P2" al codice  
Available with Thin pitch thread. Please, add "/P2" to the code.

\* Disponibile con gomma EPDM blu  
Available with EPDM blu rubber

## Piede Inox

## VULCANIZZATO

Caratteristiche: BASE VULCANIZZATA Ø 120 CON DOPPIO FISSAGGIO,  
STELO SNODATO 10°

Features: VULCANIZED BOLT/DOWN BASE Ø 120,  
DOUBLE FIXING, 10° ARTICULATED STEM

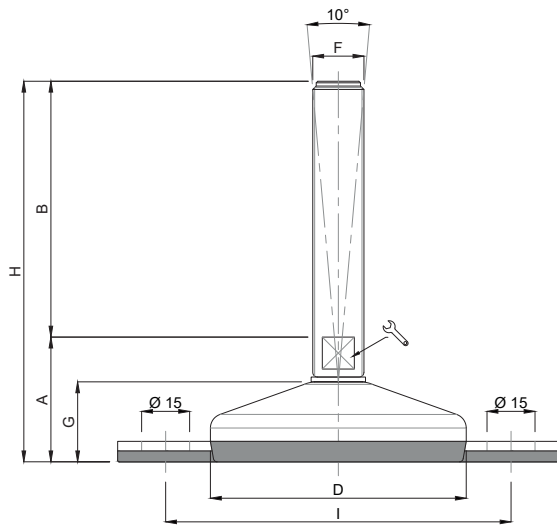

ESAGONO INTERNO IN TESTA  
TOP INTERNAL HEX

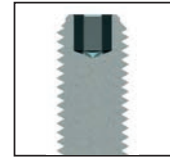

CODICE - CODE	F	HEX
.../TIH5	M10	5
.../TIH6	M12	6
.../TIH8	M16	8
.../TIH10	M20/M24/M30	10



CODICE CODE	DESCRIZIONE description	DIMENSIONI PRINCIPALI - MAIN DIMENSIONS									CARICO LOAD NEWTON
		A	B	D			F	G	H	I	
25250/FF	M16x75	47	75	Ø 120	13	-	M16	32	122	160	30000
25252/FF	M16x100	47	100	Ø 120	13	-	M16	32	147	160	30000
25254/FF	M16x125	47	125	Ø 120	13	-	M16	32	172	160	30000
25256/FF	M16x150	47	150	Ø 120	13	-	M16	32	197	160	30000
25258/FF	M16x175	47	175	Ø 120	13	-	M16	32	222	160	30000
25260/FF	M16x200	47	200	Ø 120	13	-	M16	32	247	160	30000
25262/FF	M20x75	47	75	Ø 120	17	-	M20	32	122	160	30000
25264/FF	M20x100	47	100	Ø 120	17	-	M20	32	147	160	30000
25266/FF	M20x125	47	125	Ø 120	17	-	M20	32	172	160	30000
25268/FF	M20x150	47	150	Ø 120	17	-	M20	32	197	160	30000
25270/FF	M20x175	47	175	Ø 120	17	-	M20	32	222	160	30000
25272/FF	M20x200	47	200	Ø 120	17	-	M20	32	247	160	30000
25274/FF	M20x225	47	225	Ø 120	17	-	M20	32	272	160	30000
25276/FF	M20x250	47	250	Ø 120	17	-	M20	32	297	160	30000
25278/FF	M24x100	49	100	Ø 120	20	-	M24	32	149	160	30000
25280/FF	M24x125	49	125	Ø 120	20	-	M24	32	174	160	30000
* 25282/FF	M24x150	49	150	Ø 120	20	-	M24	32	199	160	30000
* 25284/FF	M24x175	49	175	Ø 120	20	-	M24	32	224	160	30000
* 25286/FF	M24x200	49	200	Ø 120	20	-	M24	32	249	160	30000
25288/FF	M24x225	49	225	Ø 120	20	-	M24	32	274	160	30000
25290/FF	M24x250	49	250	Ø 120	20	-	M24	32	299	160	30000
25292/FF	M30x100	49	100	Ø 120	-	26	M30	32	149	160	30000
25294/FF	M30x125	49	125	Ø 120	-	26	M30	32	174	160	30000
* 25296/FF	M30x150	49	150	Ø 120	-	26	M30	32	199	160	30000
* 25298/FF	M30x175	49	175	Ø 120	-	26	M30	32	224	160	30000
* 25300/FF	M30x200	49	200	Ø 120	-	26	M30	32	249	160	30000
25302/FF	M30x225	49	225	Ø 120	-	26	M30	32	274	160	30000
25304/FF	M30x250	49	250	Ø 120	-	26	M30	32	299	160	30000

\* Disponibile con Filettatura a passo fine. Aggiungere "/P2" al codice  
Available with Thin pitch thread. Please, add "/P2" to the code.

\* Disponibile con gomma EPDM blu  
Available with EPDM blu rubber



## LINEA 15° 15° LINE

- Materiale base: acciaio Inox AISI304 (a richiesta AISI 316). A richiesta disponibile con gomma antiscivolo NBR 70 shore. Materiale Stelo: acciaio Inox AISI304 (a richiesta AISI316). Su richiesta l'elemento viene fornito con dado.
- I valori dei carichi sopra riportati sono calcolati in condizioni statiche alla metà della lunghezza dello stelo filettato. Qualora s'intendesse utilizzare i supporti in presenza di vibrazioni o carichi di movimento, tali valori dovranno essere adeguatamente ridotti. Per ulteriori chiarimenti consultare il nostro ufficio tecnico. Ogni nostra responsabilità decade in caso di manomissioni o modifiche dei componenti.
- *Material: Stainless steel base 1.4301 (1.4401 on request). On request non-slit plate in NBR rubber 70 shore is available. Stainless steel screw in 1.4301. The levelling element could be supplied, on request, with steel nut.*
- *Load values above mentioned have to be considered referring to static conditions calculated at the half of the screw length. In conditions of vibrations or in presence of dynamic load these values should be reduced. For the further information consult our technical office. We cannot accept responsibility for mounts that have been tampered or modified.*

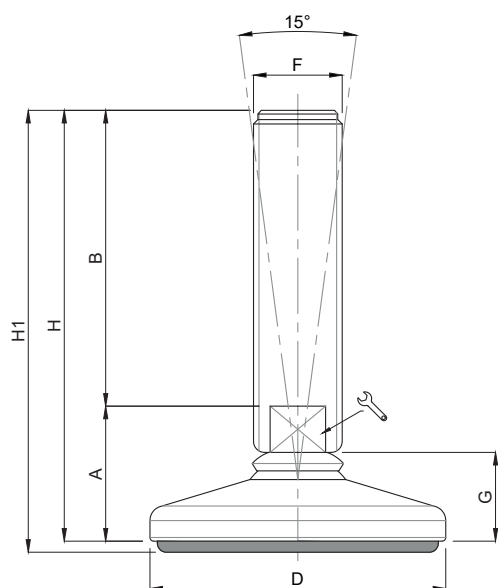

CODICE - CODE		DIMENSIONI PRINCIPALI - MAIN DIMENSIONS								CARICO STATICO STATIC LOAD NEWTON
standard standard	antiscivolo antislip	D	F	B		G	A	H	H1	
20000	20001	Ø 60	M12	50	12	24	34	84	87	20000
20002	20003	Ø 60	M12	75	12	24	34	109	112	20000
20004	20005	Ø 60	M12	100	12	24	34	134	137	20000
20006	20007	Ø 60	M12	125	12	24	34	159	162	20000
20008	20009	Ø 60	M12	150	12	24	34	184	187	20000
20010	20011	Ø 60	M12	175	12	24	34	209	212	20000
20020	20021	Ø 60	M16	50	13	24	34	84	87	30000
20022	20023	Ø 60	M16	75	13	24	34	109	112	30000
20024	20025	Ø 60	M16	100	13	24	34	134	137	30000
20026	20027	Ø 60	M16	125	13	24	34	159	162	30000
20028	20029	Ø 60	M16	150	13	24	34	184	187	30000
20030	20031	Ø 60	M16	175	13	24	34	209	212	30000
20032	20033	Ø 60	M16	200	13	24	34	234	237	30000
20034	20035	Ø 60	M16	225	13	24	34	259	262	30000
20036	20037	Ø 60	M16	250	13	24	34	284	287	30000
20040	20041	Ø 60	M20	75	17	24	36	111	114	35000
20042	20043	Ø 60	M20	100	17	24	36	136	139	35000
20044	20045	Ø 60	M20	125	17	24	36	161	164	35000
20046	20047	Ø 60	M20	150	17	24	36	186	189	35000
20048	20049	Ø 60	M20	175	17	24	36	211	214	35000
20050	20051	Ø 60	M20	200	17	24	36	236	239	35000
20052	20053	Ø 60	M20	225	17	24	36	261	264	35000
20054	20055	Ø 60	M20	250	17	24	36	286	289	35000

Su richiesta disponibile con filettatura a passo fine. Soggetto a minimo quantitativo.  
On request, available with thin pitch. Subject to minimum order quantity

Materiale base: acciaio Inox AISI304 (a richiesta AISI316).  
Materiale Stelo: acciaio Inox AISI304 (a richiesta AISI316).  
Material: Stainless steel base 1.4301 (1.4401 on request)

## Piede Inox

LINEA 15°

**Martin**  
Levelling Components

**Caratteristiche: BASE DAL PIENO Ø 80, STELO SNODATO 15°**

**Features: SOLID BASE Ø 80, 15° ARTICULATED STEM**

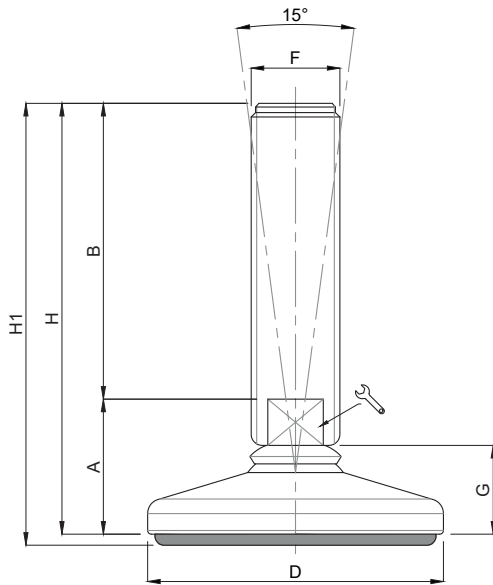

CODICE - CODE		DIMENSIONI PRINCIPALI - MAIN DIMENSIONS								CARICO STATICO STATIC LOAD NEWTON
standard standard	antiscivolo antislip	D	F	B		G	A	H	H1	
20120	20121	Ø 80	M16	50	13	24	34	84	87	30000
20122	20123	Ø 80	M16	75	13	24	34	109	112	30000
20124	20125	Ø 80	M16	100	13	24	34	134	137	30000
20126	20127	Ø 80	M16	125	13	24	34	159	162	30000
20128	20129	Ø 80	M16	150	13	24	34	184	187	30000
20130	20131	Ø 80	M16	175	13	24	34	209	212	30000
20132	20133	Ø 80	M16	200	13	24	34	234	237	30000
20134	20135	Ø 80	M16	225	13	24	34	259	262	30000
20136	20137	Ø 80	M16	250	13	24	34	284	287	30000
20140	20141	Ø 80	M20	75	17	24	36	111	114	35000
20142	20143	Ø 80	M20	100	17	24	36	136	139	35000
20144	20145	Ø 80	M20	125	17	24	36	161	164	35000
20146	20147	Ø 80	M20	150	17	24	36	186	189	35000
20148	20149	Ø 80	M20	175	17	24	36	211	214	35000
20150	20151	Ø 80	M20	200	17	24	36	236	239	35000
20152	20153	Ø 80	M20	225	17	24	36	261	264	35000
20154	20155	Ø 80	M20	250	17	24	36	286	289	35000
20160	20161	Ø 80	M24	100	20	24	36	136	139	40000
20162	20163	Ø 80	M24	125	20	24	36	161	164	40000
20164	20165	Ø 80	M24	150	20	24	36	186	189	40000
20166	20167	Ø 80	M24	175	20	24	36	211	214	40000
20168	20169	Ø 80	M24	200	20	24	36	236	239	40000
20170	20171	Ø 80	M24	225	20	24	36	261	264	40000
20172	20173	Ø 80	M24	250	20	24	36	286	289	40000

Su richiesta disponibile con filettatura a passo fine. Soggetto a minimo quantitativo.  
On request, available with thin pitch. Subject to minimum order quantity

Materiale base: acciaio Inox AISI304 (a richiesta AISI316).  
Materiale Stelo: acciaio Inox AISI304 (a richiesta AISI316).  
Material: Stainless steel base 1.4301 (1.4401 on request)

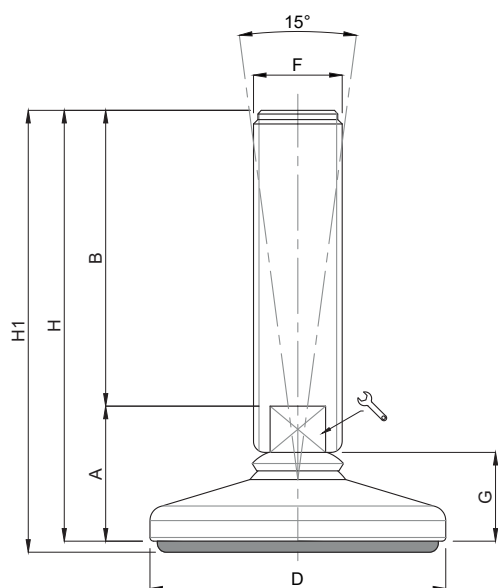

CODICE - CODE		DIMENSIONI PRINCIPALI - MAIN DIMENSIONS								CARICO STATICO STATIC LOAD NEWTON
standard standard	antiscivolo antislip	D	F	B		G	A	H	H1	
20300	20301	Ø 100	M16	50	13	24	34	84	87	30000
20302	20303	Ø 100	M16	75	13	24	34	109	112	30000
20304	20305	Ø 100	M16	100	13	24	34	134	137	30000
20306	20307	Ø 100	M16	125	13	24	34	159	162	30000
20308	20309	Ø 100	M16	150	13	24	34	184	187	30000
20310	20311	Ø 100	M16	175	13	24	34	209	212	30000
20312	20313	Ø 100	M16	200	13	24	34	234	237	30000
20314	20315	Ø 100	M16	225	13	24	34	259	262	30000
20316	20317	Ø 100	M16	250	13	24	34	284	287	30000
20320	20321	Ø 100	M20	75	17	24	36	111	114	35000
20322	20323	Ø 100	M20	100	17	24	36	136	139	35000
20324	20325	Ø 100	M20	125	17	24	36	161	164	35000
20326	20327	Ø 100	M20	150	17	24	36	186	189	35000
20328	20329	Ø 100	M20	175	17	24	36	211	214	35000
20330	20331	Ø 100	M20	200	17	24	36	236	239	35000
20332	20333	Ø 100	M20	225	17	24	36	261	264	35000
20334	20335	Ø 100	M20	250	17	24	36	286	289	35000
20340	20341	Ø 100	M24	100	20	24	36	136	139	40000
20342	20343	Ø 100	M24	125	20	24	36	161	164	40000
20344	20345	Ø 100	M24	150	20	24	36	186	189	40000
20346	20347	Ø 100	M24	175	20	24	36	211	214	40000
20348	20349	Ø 100	M24	200	20	24	36	236	239	40000
20350	20351	Ø 100	M24	225	20	24	36	261	264	40000
20352	20353	Ø 100	M24	250	20	24	36	286	289	40000
20360	20361	Ø 100	M30	100	26	24	36	136	139	50000
20362	20363	Ø 100	M30	125	26	24	36	161	164	50000
20364	20365	Ø 100	M30	150	26	24	36	186	189	50000
20366	20367	Ø 100	M30	175	26	24	36	211	214	50000
20368	20369	Ø 100	M30	200	26	24	36	236	239	50000
20370	20371	Ø 100	M30	225	26	24	36	261	264	50000
20372	20373	Ø 100	M30	250	26	24	36	286	289	50000

Su richiesta disponibile con filettatura a passo fine. Soggetto a minimo quantitativo.  
On request, available with thin pitch. Subject to minimum order quantity

Materiale base: acciaio Inox AISI304 (a richiesta AISI316). - Materiale Stelo: acciaio Inox AISI304 (a richiesta AISI316).  
Material: Stainless steel base 1.4301 (1.4401 on request)

Caratteristiche: BASE DAL PIENO Ø 120, STELO SNODATO 15°

Features: SOLID BASE Ø 120, 15° ARTICULATED STEM

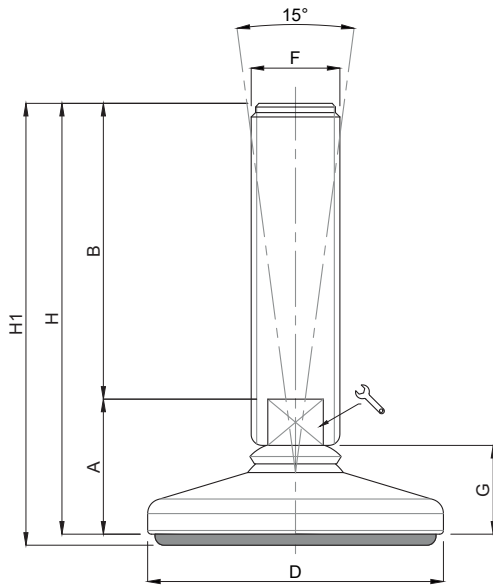

CODICE - CODE		DIMENSIONI PRINCIPALI - MAIN DIMENSIONS								CARICO STATICO STATIC LOAD NEWTON
standard standard	antiscivolo antislip	D	F	B		G	A	H	H1	
20500	20501	Ø 120	M16	50	13	24	34	84	87	30000
20502	20503	Ø 120	M16	75	13	24	34	109	112	30000
20504	20505	Ø 120	M16	100	13	24	34	134	137	30000
20506	20507	Ø 120	M16	125	13	24	34	159	162	30000
20508	20509	Ø 120	M16	150	13	24	34	184	187	30000
20510	20511	Ø 120	M16	175	13	24	34	209	212	30000
20512	20513	Ø 120	M16	200	13	24	34	234	237	30000
20514	20515	Ø 120	M16	225	13	24	34	259	262	30000
20516	20517	Ø 120	M16	250	13	24	34	284	287	30000
20520	20521	Ø 120	M20	75	17	24	36	111	114	35000
20522	20523	Ø 120	M20	100	17	24	36	136	139	35000
20524	20525	Ø 120	M20	125	17	24	36	161	164	35000
20526	20527	Ø 120	M20	150	17	24	36	186	189	35000
20528	20529	Ø 120	M20	175	17	24	36	211	214	35000
20530	20531	Ø 120	M20	200	17	24	36	236	239	35000
20532	20533	Ø 120	M20	225	17	24	36	261	264	35000
20534	20535	Ø 120	M20	250	17	24	36	286	289	35000
20540	20541	Ø 120	M24	100	20	24	36	136	139	40000
20542	20543	Ø 120	M24	125	20	24	36	161	164	40000
20544	20545	Ø 120	M24	150	20	24	36	186	189	40000
20546	20547	Ø 120	M24	175	20	24	36	211	214	40000
20548	20549	Ø 120	M24	200	20	24	36	236	239	40000
20550	20551	Ø 120	M24	225	20	24	36	261	264	40000
20552	20553	Ø 120	M24	250	20	24	36	286	289	40000
20560	20561	Ø 120	M30	100	26	24	36	136	139	50000
20562	20563	Ø 120	M30	125	26	24	36	161	164	50000
20564	20565	Ø 120	M30	150	26	24	36	186	189	50000
20566	20567	Ø 120	M30	175	26	24	36	211	214	50000
20568	20569	Ø 120	M30	200	26	24	36	236	239	50000
20570	20571	Ø 120	M30	225	26	24	36	261	264	50000
20572	20573	Ø 120	M30	250	26	24	36	286	289	50000

Su richiesta disponibile con filettatura a passo fine. Soggetto a minimo quantitativo.  
On request, available with thin pitch. Subject to minimum order quantity

Materiale base: acciaio Inox AISI304 (a richiesta AISI316). - Materiale Stelo: acciaio Inox AISI304 (a richiesta AISI316).  
Material: Stainless steel base 1.4301 (1.4401 on request)

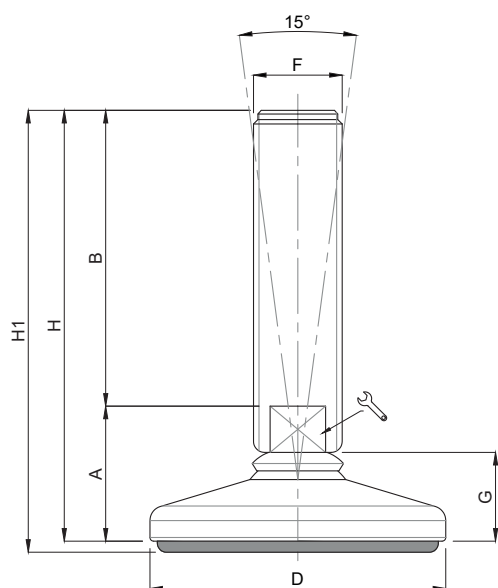

CODICE - CODE		DIMENSIONI PRINCIPALI - MAIN DIMENSIONS								CARICO STATICO STATIC LOAD NEWTON
standard standard	antiscivolo antislip	D	F	B		G	A	H	H1	
20720	20721	Ø 150	M20	75	17	24	36	111	114	35000
20722	20723	Ø 150	M20	100	17	24	36	136	139	35000
20724	20725	Ø 150	M20	125	17	24	36	161	164	35000
20726	20727	Ø 150	M20	150	17	24	36	186	189	35000
20728	20729	Ø 150	M20	175	17	24	36	211	214	35000
20730	20731	Ø 150	M20	200	17	24	36	236	239	35000
20732	20733	Ø 150	M20	225	17	24	36	261	264	35000
20734	20735	Ø 150	M20	250	17	24	36	286	289	35000
20740	20741	Ø 150	M24	100	20	24	36	136	139	40000
20742	20743	Ø 150	M24	125	20	24	36	161	164	40000
20744	20745	Ø 150	M24	150	20	24	36	186	189	40000
20746	20747	Ø 150	M24	175	20	24	36	211	214	40000
20748	20749	Ø 150	M24	200	20	24	36	236	239	40000
20750	20751	Ø 150	M24	225	20	24	36	261	264	40000
20752	20753	Ø 150	M24	250	20	24	36	286	289	40000
20760	20761	Ø 150	M30	100	26	24	36	136	139	50000
20762	20763	Ø 150	M30	125	26	24	36	161	164	50000
20764	20765	Ø 150	M30	150	26	24	36	186	189	50000
20766	20767	Ø 150	M30	175	26	24	36	211	214	50000
20768	20769	Ø 150	M30	200	26	24	36	236	239	50000
20770	20771	Ø 150	M30	225	26	24	36	261	264	50000
20772	20773	Ø 150	M30	250	26	24	36	286	289	50000

Su richiesta disponibile con filettatura a passo fine. Soggetto a minimo quantitativo.  
On request, available with thin pitch. Subject to minimum order quantity

Materiale base: acciaio Inox AISI304 (a richiesta AISI316).  
Materiale Stelo: acciaio Inox AISI304 (a richiesta AISI316).  
Material: Stainless steel base 1.4301 (1.4401 on request)

## Piede Inox

LINEA 15°

Martin  
Levelling Components

Caratteristiche: BASE DAL PIENO Ø 80 CON 2 FORI, STELO SNODATO 15°

Features: SOLID BASE Ø 80 WITH 2 BORES, 15° ARTICULATED STEM

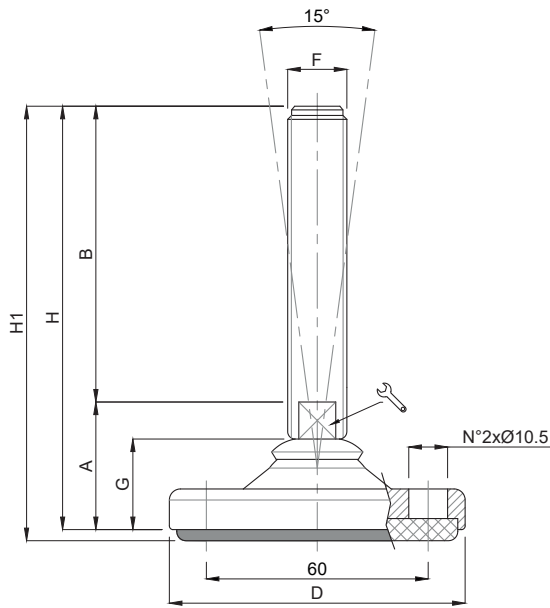

- Fornito con tappo
- Provided with cap

INOX

CODICE - CODE		DIMENSIONI PRINCIPALI - MAIN DIMENSIONS								CARICO STATICO STATIC LOAD NEWTON
standard standard	antiscivolo antislip	D	F	B		G	A	H	H1	
20120F	20121F	Ø 80	M16	50	13	24	34	84	87	30000
20122F	20123F	Ø 80	M16	75	13	24	34	109	112	30000
20124F	20125F	Ø 80	M16	100	13	24	34	134	137	30000
20126F	20127F	Ø 80	M16	125	13	24	34	159	162	30000
20128F	20129F	Ø 80	M16	150	13	24	34	184	187	30000
20130F	20131F	Ø 80	M16	175	13	24	34	209	212	30000
20132F	20133F	Ø 80	M16	200	13	24	34	234	237	30000
20134F	20135F	Ø 80	M16	225	13	24	34	259	262	30000
20136F	20137F	Ø 80	M16	250	13	24	34	284	287	30000
20140F	20141F	Ø 80	M20	75	17	24	36	111	114	35000
20142F	20143F	Ø 80	M20	100	17	24	36	136	139	35000
20144F	20145F	Ø 80	M20	125	17	24	36	161	164	35000
20146F	20147F	Ø 80	M20	150	17	24	36	186	189	35000
20148F	20149F	Ø 80	M20	175	17	24	36	211	214	35000
20150F	20151F	Ø 80	M20	200	17	24	36	236	239	35000
20152F	20153F	Ø 80	M20	225	17	24	36	261	264	35000
20154F	20155F	Ø 80	M20	250	17	24	36	286	289	35000
20160F	20161F	Ø 80	M24	100	20	24	36	136	139	40000
20162F	20163F	Ø 80	M24	125	20	24	36	161	164	40000
20164F	20165F	Ø 80	M24	150	20	24	36	186	189	40000
20166F	20167F	Ø 80	M24	175	20	24	36	211	214	40000
20168F	20169F	Ø 80	M24	200	20	24	36	236	239	40000
20170F	20171F	Ø 80	M24	225	20	24	36	261	264	40000
20172F	20173F	Ø 80	M24	250	20	24	36	286	289	40000

Su richiesta disponibile con filettatura a passo fine. Soggetto a minimo quantitativo.  
On request, available with thin pitch. Subject to minimum order quantity

Materiale base: acciaio Inox AISI304 (a richiesta AISI316).  
Materiale Stelo: acciaio Inox AISI304 (a richiesta AISI316).  
Material: Stainless steel base 1.4301 (1.4401 on request)

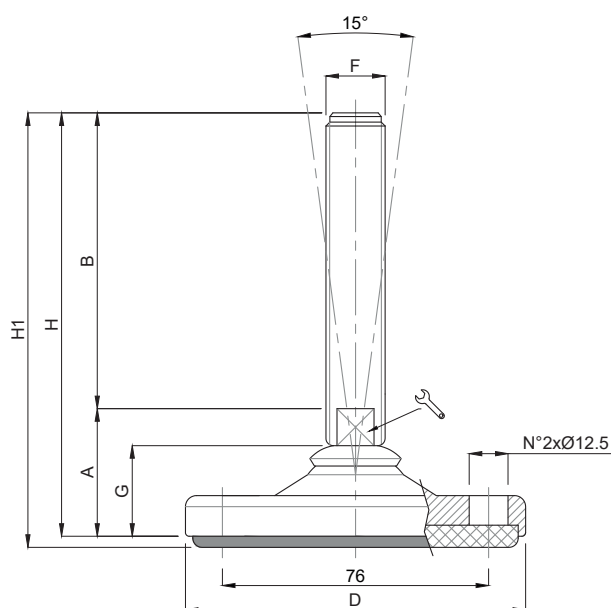

- Fornito con tappo
- Provided with cap



CODICE - CODE		DIMENSIONI PRINCIPALI - MAIN DIMENSIONS								CARICO STATICO STATIC LOAD NEWTON
standard standard	antiscivolo antislip	D	F	B		G	A	H	H1	
20300F	20301F	Ø 100	M16	50	13	24	34	84	87	30000
20302F	20303F	Ø 100	M16	75	13	24	34	109	112	30000
20304F	20305F	Ø 100	M16	100	13	24	34	134	137	30000
20306F	20307F	Ø 100	M16	125	13	24	34	159	162	30000
20308F	20309F	Ø 100	M16	150	13	24	34	184	187	30000
20310F	20311F	Ø 100	M16	175	13	24	34	209	212	30000
20312F	20313F	Ø 100	M16	200	13	24	34	234	237	30000
20314F	20315F	Ø 100	M16	225	13	24	34	259	262	30000
20316F	20317F	Ø 100	M16	250	13	24	34	284	287	30000
20320F	20321F	Ø 100	M20	75	17	24	36	111	114	35000
20322F	20323F	Ø 100	M20	100	17	24	36	136	139	35000
20324F	20325F	Ø 100	M20	125	17	24	36	161	164	35000
20326F	20327F	Ø 100	M20	150	17	24	36	186	189	35000
20328F	20329F	Ø 100	M20	175	17	24	36	211	214	35000
20330F	20331F	Ø 100	M20	200	17	24	36	236	239	35000
20332F	20333F	Ø 100	M20	225	17	24	36	261	264	35000
20334F	20335F	Ø 100	M20	250	17	24	36	286	289	35000
20340F	20341F	Ø 100	M24	100	20	24	36	136	139	40000
20342F	20343F	Ø 100	M24	125	20	24	36	161	164	40000
20344F	20345F	Ø 100	M24	150	20	24	36	186	189	40000
20346F	20347F	Ø 100	M24	175	20	24	36	211	214	40000
20348F	20349F	Ø 100	M24	200	20	24	36	236	239	40000
20350F	20351F	Ø 100	M24	225	20	24	36	261	264	40000
20352F	20353F	Ø 100	M24	250	20	24	36	286	289	40000
20360F	20361F	Ø 100	M30	100	26	24	36	136	139	50000
20362F	20363F	Ø 100	M30	125	26	24	36	161	164	50000
20364F	20365F	Ø 100	M30	150	26	24	36	186	189	50000
20366F	20367F	Ø 100	M30	175	26	24	36	211	214	50000
20368F	20369F	Ø 100	M30	200	26	24	36	236	239	50000
20370F	20371F	Ø 100	M30	225	26	24	36	261	264	50000
20372F	20373F	Ø 100	M30	250	26	24	36	286	289	50000

Su richiesta disponibile con filettatura a passo fine. Soggetto a minimo quantitativo.  
On request, available with thin pitch. Subject to minimum order quantity

Materiale base: acciaio Inox AISI304 (a richiesta AISI316). - Materiale Stelo: acciaio Inox AISI304 (a richiesta AISI316).  
Material: Stainless steel base 1.4301 (1.4401 on request)

## Piede Inox

LINEA 15°

Martin  
Levelling Components

Caratteristiche: BASE DAL PIENO Ø 120 CON 2 FORI, STELO SNODATO 15°

Features: SOLID BASE Ø 120 WITH 2 BORES, 15° ARTICULATED STEM

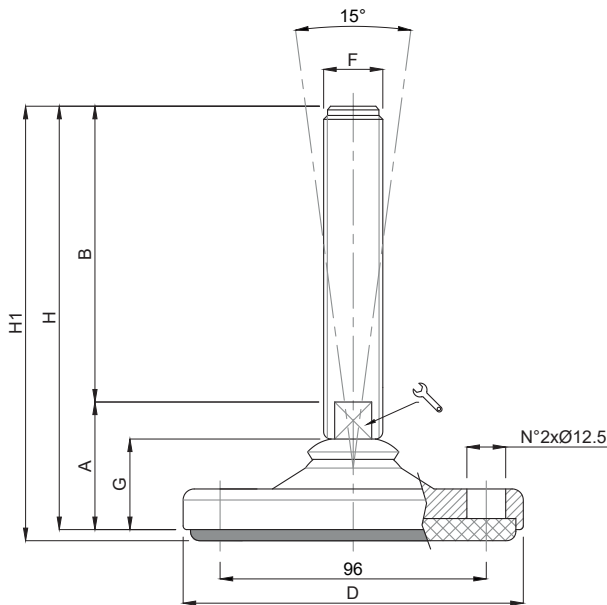

- Fornito con tappo
- Provided with cap

INOX

CODICE - CODE		DIMENSIONI PRINCIPALI - MAIN DIMENSIONS								CARICO STATICO STATIC LOAD NEWTON
standard standard	antiscivolo antislip	D	F	B		G	A	H	H1	
20500F	20501F	Ø 120	M16	50	13	24	34	84	87	30000
20502F	20503F	Ø 120	M16	75	13	24	34	109	112	30000
20504F	20505F	Ø 120	M16	100	13	24	34	134	137	30000
20506F	20507F	Ø 120	M16	125	13	24	34	159	162	30000
20508F	20509F	Ø 120	M16	150	13	24	34	184	187	30000
20510F	20511F	Ø 120	M16	175	13	24	34	209	212	30000
20512F	20513F	Ø 120	M16	200	13	24	34	234	237	30000
20514F	20515F	Ø 120	M16	225	13	24	34	259	262	30000
20516F	20517F	Ø 120	M16	250	13	24	34	284	287	30000
20520F	20521F	Ø 120	M20	75	17	24	36	111	114	35000
20522F	20523F	Ø 120	M20	100	17	24	36	136	139	35000
20524F	20525F	Ø 120	M20	125	17	24	36	161	164	35000
20526F	20527F	Ø 120	M20	150	17	24	36	186	189	35000
20528F	20529F	Ø 120	M20	175	17	24	36	211	214	35000
20530F	20531F	Ø 120	M20	200	17	24	36	236	239	35000
20532F	20533F	Ø 120	M20	225	17	24	36	261	264	35000
20534F	20535F	Ø 120	M20	250	17	24	36	286	289	35000
20540F	20541F	Ø 120	M24	100	20	24	36	136	139	40000
20542F	20543F	Ø 120	M24	125	20	24	36	161	164	40000
20544F	20545F	Ø 120	M24	150	20	24	36	186	189	40000
20546F	20547F	Ø 120	M24	175	20	24	36	211	214	40000
20548F	20549F	Ø 120	M24	200	20	24	36	236	239	40000
20550F	20551F	Ø 120	M24	225	20	24	36	261	264	40000
20552F	20553F	Ø 120	M24	250	20	24	36	286	289	40000
20560F	20561F	Ø 120	M30	100	26	24	36	136	139	50000
20562F	20563F	Ø 120	M30	125	26	24	36	161	164	50000
20564F	20565F	Ø 120	M30	150	26	24	36	186	189	50000
20566F	20567F	Ø 120	M30	175	26	24	36	211	214	50000
20568F	20569F	Ø 120	M30	200	26	24	36	236	239	50000
20570F	20571F	Ø 120	M30	225	26	24	36	261	264	50000
20572F	20573F	Ø 120	M30	250	26	24	36	286	289	50000

Su richiesta disponibile con filettatura a passo fine. Soggetto a minimo quantitativo.  
On request, available with thin pitch. Subject to minimum order quantity

Materiale base: acciaio Inox AISI304 (a richiesta AISI316). - Materiale Stelo: acciaio Inox AISI304 (a richiesta AISI316).  
Material: Stainless steel base 1.4301 (1.4401 on request)

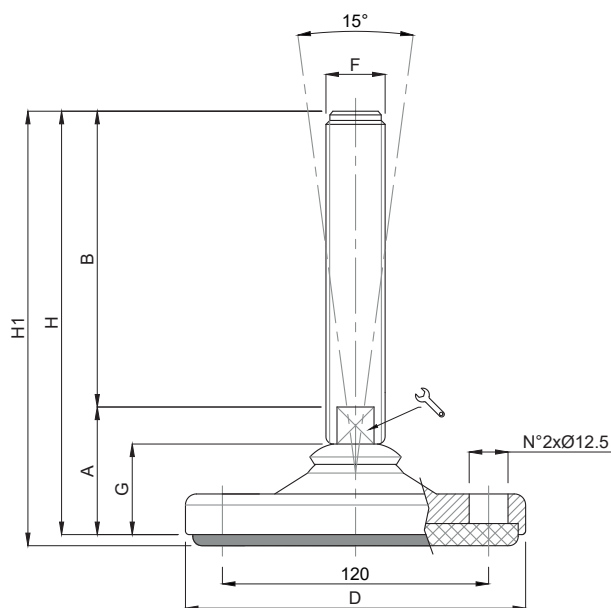

- Fornito con tappo
- Provided with cap

CODICE - CODE		DIMENSIONI PRINCIPALI - MAIN DIMENSIONS								CARICO STATICO STATIC LOAD NEWTON
standard standard	antiscivolo antislip	D	F	B		G	A	H	H1	
20720F	20721F	Ø 150	M20	75	17	24	36	111	114	35000
20722F	20723F	Ø 150	M20	100	17	24	36	136	139	35000
20724F	20725F	Ø 150	M20	125	17	24	36	161	164	35000
20726F	20727F	Ø 150	M20	150	17	24	36	186	189	35000
20728F	20729F	Ø 150	M20	175	17	24	36	211	214	35000
20730F	20731F	Ø 150	M20	200	17	24	36	236	239	35000
20732F	20733F	Ø 150	M20	225	17	24	36	261	264	35000
20734F	20735F	Ø 150	M20	250	17	24	36	286	289	35000
20740F	20741F	Ø 150	M24	100	20	24	36	136	139	40000
20742F	20743F	Ø 150	M24	125	20	24	36	161	164	40000
20744F	20745F	Ø 150	M24	150	20	24	36	186	189	40000
20746F	20747F	Ø 150	M24	175	20	24	36	211	214	40000
20748F	20749F	Ø 150	M24	200	20	24	36	236	239	40000
20750F	20751F	Ø 150	M24	225	20	24	36	261	264	40000
20752F	20753F	Ø 150	M24	250	20	24	36	286	289	40000
20760F	20761F	Ø 150	M30	100	26	24	36	136	139	50000
20762F	20763F	Ø 150	M30	125	26	24	36	161	164	50000
20764F	20765F	Ø 150	M30	150	26	24	36	186	189	50000
20766F	20767F	Ø 150	M30	175	26	24	36	211	214	50000
20768F	20769F	Ø 150	M30	200	26	24	36	236	239	50000
20770F	20771F	Ø 150	M30	225	26	24	36	261	264	50000
20772F	20773F	Ø 150	M30	250	26	24	36	286	289	50000

Su richiesta disponibile con filettatura a passo fine. Soggetto a minimo quantitativo.  
On request, available with thin pitch. Subject to minimum order quantity

Materiale base: acciaio Inox AISI304 (a richiesta AISI316).  
Materiale Stelo: acciaio Inox AISI304 (a richiesta AISI316).  
Material: Stainless steel base 1.4301 (1.4401 on request)

## MEDIA PORTATA MEDIUM LOAD

- Materiale base: acciaio inox AISI 304 (a richiesta AISI 316). A richiesta disponibile con gomma antiscivolo NBR 70 shore (codice standard = senza gomma). Materiale stelo: acciaio inox AISI 304 (a richiesta AISI 316). Su richiesta l'elemento di livellamento viene fornito con dado in acciaio.
- I valori dei carichi sopra riportati sono calcolati in condizioni statiche alla metà della lunghezza dello stelo filettato. Qualora s'intendesse utilizzare i supporti in presenza di vibrazioni o carichi in movimento, tali valori dovranno essere adeguatamente ridotti. Per ulteriori chiarimenti consultare il nostro ufficio tecnico. Ogni nostra responsabilità decade in caso di manomissioni o modifiche dei componenti.
- *Stainless steel base in 1.4301 (1.4401 on specific request). Black non-skid plate in NBR rubber 90 shore. Stainless steel screw in 1.4301 (1.4401 on specific request). The leveling element could be supplied, on request, with steel nut.*
- *Load values above mentioned have to be considered referring to static conditions calculated at the half of the screw length. In conditions of vibrations or in presence of dynamic loads these values should be reduced. For further information consult our technical office. We cannot accept responsibility for mounts that have been tampered or modified*

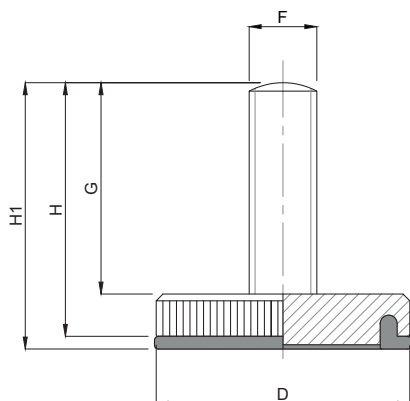



CODICE - CODE		descrizione - description	DIMENSIONI PRINCIPALI - MAIN DIMENSIONS					CARICO STATICO STATIC LOAD NEWTON
standard standard	antiscivolo antislip		D	F	G	H	H1	
3021	3021/G	PIEDINO FISSO M6x12	24	M6	12	17	17,5	5000
3022	3022/G	PIEDINO FISSO M6x16	24	M6	16	21	21,5	5000
3023	3023/G	PIEDINO FISSO M6x20	24	M6	20	25	25,5	5000
3024	3024/G	PIEDINO FISSO M6x25	24	M6	25	30	30,5	5000
3025	3025/G	PIEDINO FISSO M6x30	24	M6	30	35	35,5	5000
3026	3026/G	PIEDINO FISSO M8x12	30	M8	12	18	18,5	6000
3027	3027/G	PIEDINO FISSO M8x16	30	M8	16	22	22,5	6000
3028	3028/G	PIEDINO FISSO M8x20	30	M8	20	26	26,5	6000
3029	3029/G	PIEDINO FISSO M8x25	30	M8	25	31	31,5	6000
3030	3030/G	PIEDINO FISSO M8x30	30	M8	30	36	36,5	6000

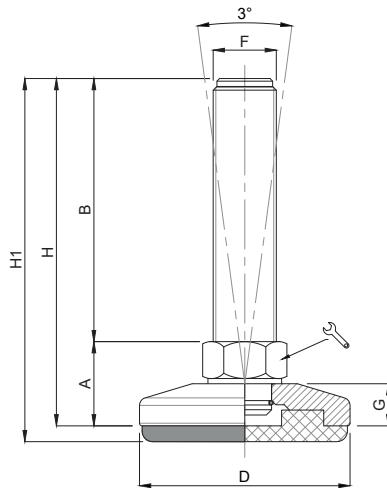

Caratteristiche: BASE DAL PIENO Ø30/40, STELO SNODATO 2/3°

Features: SOLID BASE Ø30/40, TILTED STEM 2/3°



CODICE - CODE		descrizione description	DIMENSIONI PRINCIPALI - MAIN DIMENSIONS								CARICO STATICO STATIC LOAD NEWTON
standard standard	antiscivolo antislip		A	B	D		F	G	H	H1	
30825	30825/G	M8X25	14	25	Ø 30	14	M8	8	39	42	8000
30850	30850/G	M8X50	14	50	Ø 30	14	M8	8	64	67	8000
301025	301025/G	M10X25	14	25	Ø 30	14	M10	8	39	42	8000
301050	301050/G	M10X50	14	50	Ø 30	14	M10	8	64	67	8000
301075	301075/G	M10X75	14	75	Ø 30	14	M10	8	89	92	8000
38825	38825/G	M8X25	14	25	Ø 40	14	M8	8	39	42	9000
38850	38850/G	M8X50	14	50	Ø 40	14	M8	8	64	67	9000
381025	381025/G	M10X25	14	25	Ø 40	14	M10	8	39	42	9000
381050	381050/G	M10X50	14	50	Ø 40	14	M10	8	64	67	9000
381075	381075/G	M10X75	14	75	Ø 40	14	M10	8	89	92	9000
381250	381250/G	M12X50	14	50	Ø 40	14	M12	8	64	67	9000
3812100	3812100/G	M12X100	14	100	Ø 40	14	M12	8	114	117	9000

• Materiale base: acciaio inox AISI 304 (a richiesta AISI 316). Elemento fornito con gomma antiscivolo NBR 70 shore. Materiale stelo: acciaio inox AISI 304 (a richiesta AISI 316). Su richiesta l'elemento di livellamento viene fornito con dado in acciaio.

• I valori dei carichi sopra riportati sono calcolati in condizioni statiche alla metà della lunghezza dello stelo filettato. Qualora s'intendesse utilizzare i supporti in presenza di vibrazioni o carichi in movimento, tali valori dovranno essere adeguatamente ridotti. Per ulteriori chiarimenti consultare il nostro ufficio tecnico. Ogni nostra responsabilità decade in caso di manomissioni o modifiche dei componenti.

• Stainless steel base in 1.4301 (1.4401 on specific request). Leveling element supplied with black non-skid plate in NBR rubber 70 shore. Stainless steel screw in 1.4301 (1.4401 on specific request). The leveling element could be supplied, on request, with steel nut.

• Load values above mentioned have to be considered referring to static conditions calculated at the half of the screw length. In conditions of vibrations or in presence of dynamic loads these values should be reduced. For further information consult our technical office. We cannot accept responsibility for mounts that have been tampered or modified

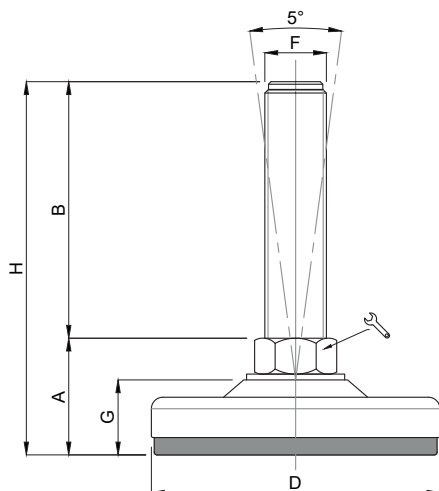

CODICE - CODE	descrizione	DIMENSIONI PRINCIPALI - MAIN DIMENSIONS							CARICO STATICO STATIC LOAD NEWTON
		A	B	D		F	G	H	
15000/50	M10X25	23	25	Ø 50	14	M10	13	48	12000
15001/50	M10X50	23	50	Ø 50	14	M10	13	73	12000
15002/50	M10X75	23	75	Ø 50	14	M10	13	98	12000
15003/50	M10X100	23	100	Ø 50	14	M10	13	123	12000
15004/50	M12X25	23	25	Ø 50	14	M12	13	48	12000
15005/50	M12X50	23	50	Ø 50	14	M12	13	73	12000
15006/50	M12X75	23	75	Ø 50	14	M12	13	98	12000
15007/50	M12X100	23	100	Ø 50	14	M12	13	123	12000
15008/50	M12X125	23	125	Ø 50	14	M12	13	148	12000
15009/50	M14X50	23	50	Ø 50	14	M14	13	73	12000
15010/50	M14X75	23	75	Ø 50	14	M14	13	98	12000
15011/50	M14X100	23	100	Ø 50	14	M14	13	123	12000
15012/50	M14X125	23	125	Ø 50	14	M14	13	148	12000
15013/50	M14X150	23	150	Ø 50	14	M14	13	173	12000

• Materiale base: acciaio inox AISI 304 (a richiesta AISI 316). Elemento fornito con gomma antiscivolo NBR 70 shore. Materiale stelo: acciaio inox AISI 304 (a richiesta AISI 316). Su richiesta l'elemento di livellamento viene fornito con dado in acciaio.

• I valori dei carichi sopra riportati sono calcolati in condizioni statiche alla metà della lunghezza dello stelo filettato. Qualora s'intendesse utilizzare i supporti in presenza di vibrazioni o carichi in movimento, tali valori dovranno essere adeguatamente ridotti. Per ulteriori chiarimenti consultare il nostro ufficio tecnico. Ogni nostra responsabilità decade in caso di manomissioni o modifiche dei componenti.

• Stainless steel base in 1.4301 (1.4401 on specific request). Leveling element supplied with black non-skid plate in NBR rubber 70 shore. Stainless steel screw in 1.4301 (1.4401 on specific request). The leveling element could be supplied, on request, with steel nut.

• Load values above mentioned have to be considered referring to static conditions calculated at the half of the screw length. In conditions of vibrations or in presence of dynamic loads these values should be reduced. For further information consult our technical office. We cannot accept responsibility for mounts that have been tampered or modified

Caratteristiche: BASE DAL PIENO Ø 60, STELO SNODATO 5°

Features: SOLID BASE Ø 60, 5° ARTICULATED STEM

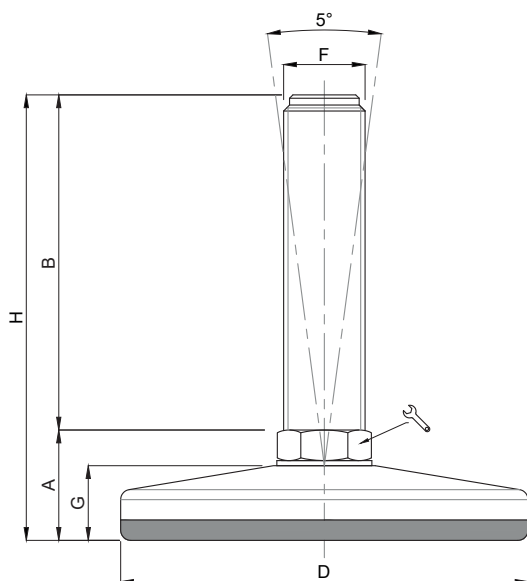

CODICE - CODE	descrizione	DIMENSIONI PRINCIPALI - MAIN DIMENSIONS							CARICO STATICO STATIC LOAD NEWTON
		A	B	D		F	G	H	
15000	M10X25	24,5	25	Ø 60	14	M10	17,5	49,5	15000
15001	M10X50	24,5	50	Ø 60	14	M10	17,5	74,5	15000
15002	M10X75	24,5	75	Ø 60	14	M10	17,5	99,5	15000
15003	M10X100	24,5	100	Ø 60	14	M10	17,5	124,5	15000
15004	M12X25	24,5	25	Ø 60	14	M12	17,5	49,5	15000
15005	M12X50	24,5	50	Ø 60	14	M12	17,5	74,5	15000
15006	M12X75	24,5	75	Ø 60	14	M12	17,5	99,5	15000
15007	M12X100	24,5	100	Ø 60	14	M12	17,5	124,5	15000
15008	M12X125	24,5	125	Ø 60	14	M12	17,5	149,5	15000
15009	M14X50	24,5	50	Ø 60	14	M14	17,5	74,5	15000
15010	M14X75	24,5	75	Ø 60	14	M14	17,5	99,5	15000
15011	M14X100	24,5	100	Ø 60	14	M14	17,5	124,5	15000
15012	M14X125	24,5	125	Ø 60	14	M14	17,5	149,5	15000
15013	M14X150	24,5	150	Ø 60	14	M14	17,5	174,5	15000
15009/16	M16X50	30	50	Ø 60	13	M16	17,5	80	20000
15010/16	M16X75	30	75	Ø 60	13	M16	17,5	105	20000
15011/16	M16X100	30	100	Ø 60	13	M16	17,5	130	20000
15012/16	M16X125	30	125	Ø 60	13	M16	17,5	155	20000
15013/16	M16X150	30	150	Ø 60	13	M16	17,5	180	20000
15014/16	M16X175	30	175	Ø 60	13	M16	17,5	205	20000

- Materiale base: acciaio inox AISI 304 (a richiesta AISI 316). Elemento fornito con gomma antiscivolo NBR 90 shore. Materiale stelo: acciaio inox AISI 304 (a richiesta AISI 316). Su richiesta l'elemento di livellamento viene fornito con dado in acciaio.
- I valori dei carichi sopra riportati sono calcolati in condizioni statiche alla metà della lunghezza dello stelo filettato. Qualora s'intendesse utilizzare i supporti in presenza di vibrazioni o carichi in movimento, tali valori dovranno essere adeguatamente ridotti. Per ulteriori chiarimenti consultare il nostro ufficio tecnico. Ogni nostra responsabilità decade in caso di manomissioni o modifiche dei componenti.
- *Stainless steel base in 1.4301 (1.4401 on specific request). Leveling element supplied with black non-skid plate in NBR rubber 90 shore. Stainless steel screw in 1.4301 (1.4401 on specific request). The leveling element could be supplied, on request, with steel nut.*
- *Load values above mentioned have to be considered referring to static conditions calculated at the half of the screw length. In conditions of vibrations or in presence of dynamic loads these values should be reduced. For further information consult our technical office. We cannot accept responsibility for mounts that have been tampered or modified*

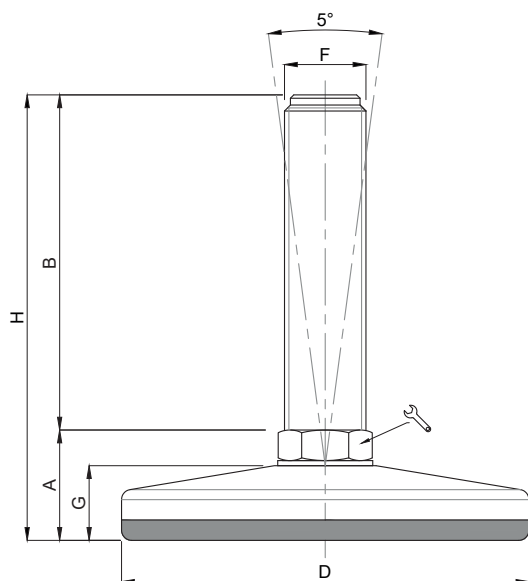



CODICE - CODE antiscivolo - antislip	descrizione description	DIMENSIONI PRINCIPALI - MAIN DIMENSIONS							CARICO STATICO STATIC LOAD NEWTON
		A	B	D		F	G	H	
15014	M12X50	28	50	Ø 75	14	M12	20	78	20000
15015	M12X75	28	75	Ø 75	14	M12	20	103	20000
15016	M12X100	28	100	Ø 75	14	M12	20	128	20000
15017	M12X125	28	125	Ø 75	14	M12	20	153	20000
15018	M14X50	28	50	Ø 75	14	M14	20	78	20000
15019	M14X75	28	75	Ø 75	14	M14	20	103	20000
15020	M14X100	28	100	Ø 75	14	M14	20	128	20000
15021	M14X125	28	125	Ø 75	14	M14	20	153	20000
15022	M14X150	28	150	Ø 75	14	M14	20	178	20000
15023	M16X50	32,5	50	Ø 75	13*	M16	20	82,5	20000
15024	M16X75	32,5	75	Ø 75	13*	M16	20	107,5	20000
15025	M16X100	32,5	100	Ø 75	13*	M16	20	132,5	20000
15026	M16X125	32,5	125	Ø 75	13*	M16	20	157,5	20000
15027	M16X150	32,5	150	Ø 75	13*	M16	20	182,5	20000
15028	M16X175	32,5	175	Ø 75	13*	M16	20	207,5	20000
15029	M20X50	32,5	50	Ø 75	17*	M20	20	82,5	20000
15030	M20X75	32,5	75	Ø 75	17*	M20	20	107,5	20000
15031	M20X100	32,5	100	Ø 75	17*	M20	20	132,5	20000
15032	M20X125	32,5	125	Ø 75	17*	M20	20	157,5	20000
15033	M20X150	32,5	150	Ø 75	17*	M20	20	182,5	20000
15034	M20X175	32,5	175	Ø 75	17*	M20	20	207,5	20000
15035	M20X200	32,5	200	Ø 75	17*	M20	20	232,5	20000
15036	M20X225	32,5	225	Ø 75	17*	M20	20	257,5	20000

\* Chiave ottenuta da barra tonda  
Wrench from round bar

Caratteristiche: BASE DAL PIENO Ø 100, STELO SNODATO 5°

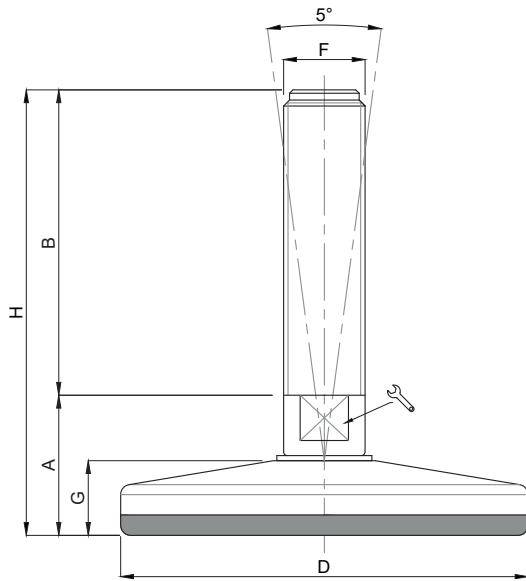
Features: SOLID BASE Ø 100, 5° ARTICULATED STEM



CODICE - CODE antiscivolo - antislip	descrizione description	DIMENSIONI PRINCIPALI - MAIN DIMENSIONS							CARICO STATICO STATIC LOAD NEWTON
		A	B	D		F	G	H	
15037	M16X50	37	50	Ø 100	17	M16	24	87	30000
15038	M16X75	37	75	Ø 100	17	M16	24	112	30000
15039	M16X100	37	100	Ø 100	17	M16	24	137	30000
15040	M16X125	37	125	Ø 100	17	M16	24	162	30000
15041	M16X150	37	150	Ø 100	17	M16	24	187	30000
15042	M16X175	37	175	Ø 100	17	M16	24	212	30000
15043	M16X200	37	200	Ø 100	17	M16	24	237	30000
15044	M16X225	37	225	Ø 100	17	M16	24	262	30000
15045	M20X50	37	50	Ø 100	17	M20	24	87	30000
15046	M20X75	37	75	Ø 100	17	M20	24	112	30000
15047	M20X100	37	100	Ø 100	17	M20	24	137	30000
15048	M20X125	37	125	Ø 100	17	M20	24	162	30000
15049	M20X150	37	150	Ø 100	17	M20	24	187	30000
15050	M20X175	37	175	Ø 100	17	M20	24	212	30000
15051	M20X200	37	200	Ø 100	17	M20	24	237	30000
15052	M20X225	37	225	Ø 100	17	M20	24	262	30000
15053	M20X250	37	250	Ø 100	17	M20	24	287	30000
15054	M24X75	38	75	Ø 100	20	M24	24	113	30000
15055	M24X100	38	100	Ø 100	20	M24	24	138	30000
15056	M24X125	38	125	Ø 100	20	M24	24	163	30000
* 15057	M24X150	38	150	Ø 100	20	M24	24	188	30000
15058	M24X175	38	175	Ø 100	20	M24	24	213	30000
* 15059	M24X200	38	200	Ø 100	20	M24	24	238	30000
15060	M24X225	38	225	Ø 100	20	M24	24	263	30000
15061	M24X250	38	250	Ø 100	20	M24	24	288	30000

\* Disponibile con Filettatura a passo fine. Aggiungere "/P2" al codice  
Available with Thin pitch thread. Please, add "/P2" to the code

• Materiale base: acciaio inox AISI 304 (a richiesta AISI 316). Elemento fornito con gomma antiscivolo NBR 90 shore. Materiale stelo: acciaio inox AISI 304 (a richiesta AISI 316). Su richiesta l'elemento di livellamento viene fornito con dado in acciaio.

• I valori dei carichi sopra riportati sono calcolati in condizioni statiche alla metà della lunghezza dello stelo filettato. Qualora s'intendesse utilizzare i supporti in presenza di vibrazioni o carichi in movimento, tali valori dovranno essere adeguatamente ridotti. Per ulteriori chiarimenti consultare il nostro ufficio tecnico. Ogni nostra responsabilità decade in caso di manomissioni o modifiche dei componenti.

• Stainless steel base in 1.4301 (1.4401 on specific request). Levelling element supplied with black non-skid plate in NBR rubber 90 shore. Stainless steel screw in 1.4301 (1.4401 on specific request). The levelling element could be supplied, on request, with steel nut.

• Load values above mentioned have to be considered referring to static conditions calculated at the half of the screw length. In conditions of vibrations or in presence of dynamic loads these values should be reduced. For further information consult our technical office. We cannot accept responsibility for mounts that have been tampered or modified

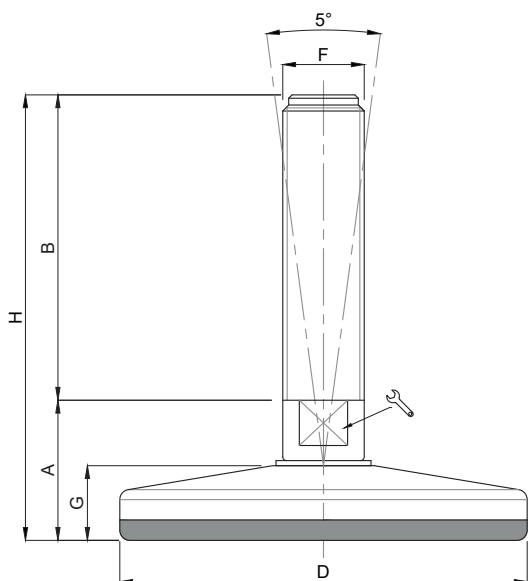



CODICE - CODE antiscivolo - antislip	descrizione description	DIMENSIONI PRINCIPALI - MAIN DIMENSIONS							CARICO STATICO STATIC LOAD NEWTON
		A	B	D		F	G	H	
15062	M16X50	36,5	50	Ø 120	17	M16	24	86,5	40000
15063	M16X75	36,5	75	Ø 120	17	M16	24	111,5	40000
15064	M16X100	36,5	100	Ø 120	17	M16	24	136,5	40000
15065	M16X125	36,5	125	Ø 120	17	M16	24	161,5	40000
15066	M16X150	36,5	150	Ø 120	17	M16	24	186,5	40000
15067	M16X175	36,5	175	Ø 120	17	M16	24	211,5	40000
15068	M16X200	36,5	200	Ø 120	17	M16	24	236,5	40000
15069	M16X225	36,5	225	Ø 120	17	M16	24	261,5	40000
15070	M20X75	36,5	75	Ø 120	17	M20	24	111,5	40000
15071	M20X100	36,5	100	Ø 120	17	M20	24	136,5	40000
15072	M20X125	36,5	125	Ø 120	17	M20	24	161,5	40000
15073	M20X150	36,5	150	Ø 120	17	M20	24	186,5	40000
15074	M20X175	36,5	175	Ø 120	17	M20	24	211,5	40000
15075	M20X200	36,5	200	Ø 120	17	M20	24	236,5	40000
15076	M20X225	36,5	225	Ø 120	17	M20	24	261,5	40000
15077	M20X250	36,5	250	Ø 120	17	M20	24	286,5	40000
15078	M24X75	37,5	75	Ø 120	20	M24	24	112,5	40000
15079	M24X100	37,5	100	Ø 120	20	M24	24	137,5	40000
15080	M24X125	37,5	125	Ø 120	20	M24	24	162,5	40000
* 15081	M24X150	37,5	150	Ø 120	20	M24	24	187,5	40000
* 15082	M24X175	37,5	175	Ø 120	20	M24	24	212,5	40000
* 15083	M24X200	37,5	200	Ø 120	20	M24	24	237,5	40000
15084	M24X225	37,5	225	Ø 120	20	M24	24	262,5	40000
15085	M24X250	37,5	250	Ø 120	20	M24	24	287,5	40000
15086	M30X75	37,5	75	Ø 120	26	M30	24	112,5	40000
15087	M30X100	37,5	100	Ø 120	26	M30	24	137,5	40000
15088	M30X125	37,5	125	Ø 120	26	M30	24	162,5	40000
* 15089	M30X150	37,5	150	Ø 120	26	M30	24	187,5	40000
* 15090	M30X175	37,5	175	Ø 120	26	M30	24	212,5	40000
* 15091	M30X200	37,5	200	Ø 120	26	M30	24	237,5	40000
15092	M30X225	37,5	225	Ø 120	26	M30	24	262,5	40000
15093	M30X250	37,5	250	Ø 120	26	M30	24	287,5	40000

\* Disponibile con Filettatura a passo fine. Aggiungere "/P2" al codice  
Available with Thin pitch thread. Please, add "/P2" to the code

Caratteristiche: BASE DAL PIENO Ø 150, STELO SNODATO 5°

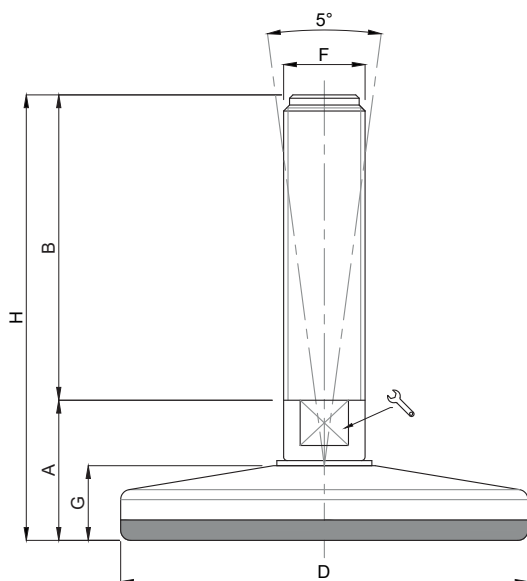
Features: SOLID BASE Ø 150, 5° ARTICULATED STEM



CODICE - CODE	descrizione	DIMENSIONI PRINCIPALI - MAIN DIMENSIONS							CARICO STATICO STATIC LOAD NEWTON
		A	B	D		F	G	H	
15094	M20X75	39	75	Ø 150	17	M20	26,5	114	50000
15095	M20X100	39	100	Ø 150	17	M20	26,5	139	50000
15096	M20X125	39	125	Ø 150	17	M20	26,5	164	50000
15097	M20X150	39	150	Ø 150	17	M20	26,5	189	50000
15098	M20X175	39	175	Ø 150	17	M20	26,5	214	50000
15099	M20X200	39	200	Ø 150	17	M20	26,5	239	50000
15100	M20X225	39	225	Ø 150	17	M20	26,5	264	50000
15101	M20X250	39	250	Ø 150	17	M20	26,5	289	50000
15102	M24X100	40	100	Ø 150	20	M24	26,5	140	50000
15103	M24X125	40	125	Ø 150	20	M24	26,5	165	50000
* 15104	M24X150	40	150	Ø 150	20	M24	26,5	190	50000
15105	M24X175	40	175	Ø 150	20	M24	26,5	215	50000
* 15106	M24X200	40	200	Ø 150	20	M24	26,5	240	50000
15107	M24X225	40	225	Ø 150	20	M24	26,5	265	50000
15108	M24X250	40	250	Ø 150	20	M24	26,5	290	50000
15109	M30X100	40	100	Ø 150	26	M30	26,5	140	50000
15110	M30X125	40	125	Ø 150	26	M30	26,5	165	50000
* 15111	M30X150	40	150	Ø 150	26	M30	26,5	190	50000
15112	M30X175	40	175	Ø 150	26	M30	26,5	215	50000
* 15113	M30X200	40	200	Ø 150	26	M30	26,5	240	50000
15114	M30X225	40	225	Ø 150	26	M30	26,5	265	50000
15115	M30X250	40	250	Ø 150	26	M30	26,5	290	50000

\* Disponibile con Filettatura a passo fine. Aggiungere "/P2" al codice  
Available with Thin pitch thread. Please, add "/P2" to the code

- Materiale base: acciaio inox AISI 304 (a richiesta AISI 316). Elemento fornito con gomma antiscivolo NBR 90 shore. Materiale stelo: acciaio inox AISI 304 (a richiesta AISI 316). Su richiesta l'elemento di livellamento viene fornito con dado in acciaio.
- I valori dei carichi sopra riportati sono calcolati in condizioni statiche alla metà della lunghezza dello stelo filettato. Qualora s'intendesse utilizzare i supporti in presenza di vibrazioni o carichi in movimento, tali valori dovranno essere adeguatamente ridotti. Per ulteriori chiarimenti consultare il nostro ufficio tecnico. Ogni nostra responsabilità decade in caso di manomissioni o modifiche dei componenti.
- Stainless steel base in 1.4301 (1.4401 on specific request). Levelling element supplied with black non-skid plate in NBR rubber 90 shore. Stainless steel screw in 1.4301 (1.4401 on specific request). The leveling element could be supplied, on request, with steel nut.
- Load values above mentioned have to be considered referring to static conditions calculated at the half of the screw length. In conditions of vibrations or in presence of dynamic loads these values should be reduced. For further information consult our technical office. We cannot accept responsibility for mounts that have been tampered or modified

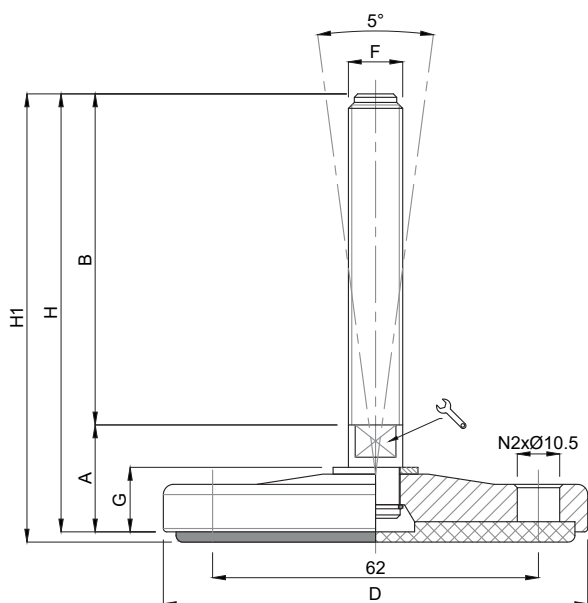

- Fornito con tappo
- Provided with cap



CODICE - CODE		DESCRIZIONE description	DIMENSIONI PRINCIPALI MAIN DIMENSIONS								CARICO STATICO STATIC LOAD NEWTON
standard standard	antiscivolo antislip		A	B	D		F	G	H	H1	
15200	15200/G	M14x50	20	50	ø 80	14	M14	11,5	70	73	20000
15201	15201/G	M14x100	20	100	ø 80	14	M14	11,5	120	123	20000
15202	15202/G	M14x150	20	150	ø 80	14	M14	11,5	170	173	20000
15203	15203/G	M16x75	20	75	ø 80	13*	M16	11,5	95	98	20000
15204	15204/G	M16x100	20	100	ø 80	13*	M16	11,5	120	123	20000
15205	15205/G	M16x150	20	150	ø 80	13*	M16	11,5	170	173	20000
15206	15206/G	M20x75	24	75	ø 80	17*	M20	11,5	99	102	25000
15207	15207/G	M20x125	24	125	ø 80	17*	M20	11,5	149	152	25000
15208	15208/G	M20x175	24	175	ø 80	17*	M20	11,5	199	202	25000

\* N°2 fresature  
Two flat sides

• Materiale base: acciaio inox AISI 304 (a richiesta AISI 316) finitura: tornitura fine. A richiesta disponibile con gomma antiscivolo NBR 70 shore. Materiale stelo: acciaio inox AISI 304 (a richiesta AISI 316). Su richiesta l'elemento di livellamento viene fornito con dado in acciaio.

• I valori dei carichi sopra riportati sono calcolati in condizioni statiche alla metà della lunghezza dello stelo filettato. Qualora s'intendesse utilizzare i supporti in presenza di vibrazioni o carichi in movimento, tali valori dovranno essere adeguatamente ridotti. Per ulteriori chiarimenti consultare il nostro ufficio tecnico. Ogni nostra responsabilità decade in caso di manomissioni o modifiche dei componenti.

• Stainless steel base in 1.4301 (1.4401 on specific request). Turning surface finishing. Stainless steel screw in 1.4301 (1.4401 on specific request). The leveling element could be supplied, on request, with steel nut.

• Load values above mentioned have to be considered referring to static conditions calculated at the half of the screw length. In conditions of vibrations or in presence of dynamic loads these values should be reduced. For further information consult our technical office. We cannot accept responsibility for mounts that have been tampered or modified

## Piede Inox

## MEDIA PORTATA

**Caratteristiche: BASE DAL PIENO Ø 100 CON 2 FORI, STELO SNODATO 5°**

**Features: SOLID BASE Ø 100 WITH 2 BORES, 5° ARTICULATED STEM**

**Martin**  
Levelling Components

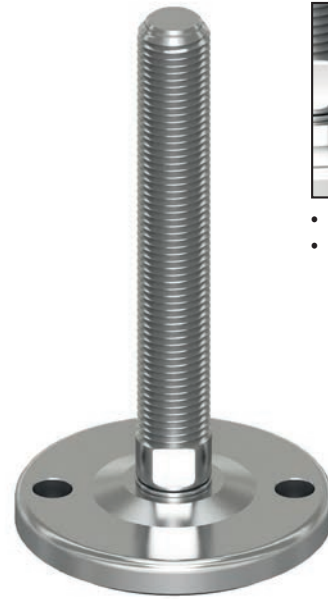
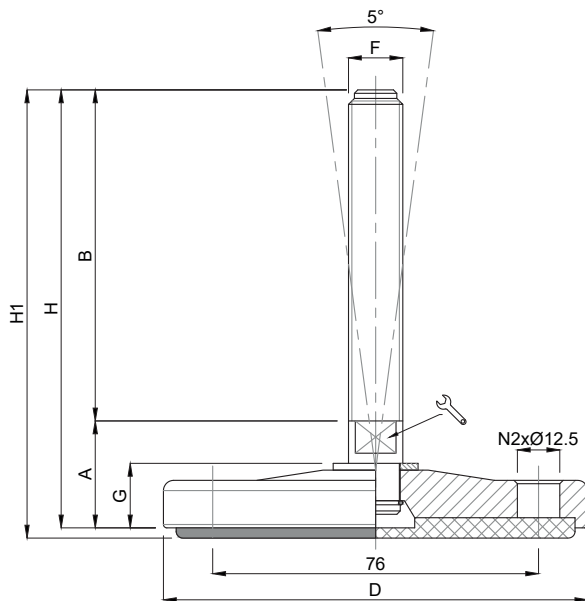

- Fornito con tappo
- Provided with cap

INOX

CODICE - CODE		DESCRIZIONE description	DIMENSIONI PRINCIPALI MAIN DIMENSIONS								CARICO STATICO STATIC LOAD NEWTON
standard standard	antiscivolo antislip		A	B	D		F	G	H	H1	
15209	15209/G	M16x75	29	75	ø 100	17	M16	16,5	104	107	30000
15210	15210/G	M16x100	29	100	ø 100	17	M16	16,5	129	132	30000
15211	15211/G	M16x150	29	150	ø 100	17	M16	16,5	179	182	30000
15212	15212/G	M20x75	29	75	ø 100	17	M20	16,5	104	107	30000
15213	15213/G	M20x125	29	125	ø 100	17	M20	16,5	154	157	30000
15214	15214/G	M20x175	29	175	ø 100	17	M20	16,5	204	207	30000
15215	15215/G	M24x100	30	100	ø 100	20	M24	16,5	130	133	35000
**	15216	15216/G	30	150	ø 100	20	M24	16,5	180	183	35000
**	15217	15217/G	30	200	ø 100	20	M24	16,5	230	233	35000
15218	15218/G	M30x125	30	125	ø 100	26	M30	16,5	155	158	35000
**	15219	15219/G	30	175	ø 100	26	M30	16,5	205	208	35000
**	15220	15220/G	30	225	ø 100	26	M30	16,5	255	258	35000

\*\* Disponibile con Filettatura a passo fine. Aggiungere "/P2" al codice  
Available with Thin pitch thread. Please, add "/P2" to the code

• Materiale base: acciaio inox AISI 304 (a richiesta AISI 316) finitura: tornitura fine. A richiesta disponibile con gomma antiscivolo NBR 70 shore. Materiale stelo: acciaio inox AISI 304 (a richiesta AISI 316). Su richiesta l'elemento di livellamento viene fornito con dado in acciaio.

• I valori dei carichi sopra riportati sono calcolati in condizioni statiche alla metà della lunghezza dello stelo filettato. Qualora s'intendesse utilizzare i supporti in presenza di vibrazioni o carichi in movimento, tali valori dovranno essere adeguatamente ridotti. Per ulteriori chiarimenti consultare il nostro ufficio tecnico. Ogni nostra responsabilità decade in caso di manomissioni o modifiche dei componenti.

• Stainless steel base in 1.4301 (1.4401 on specific request). Turning surface finishing. Stainless steel screw in 1.4301 (1.4401 on specific request). The leveling element could be supplied, on request, with steel nut.

• Load values above mentioned have to be considered referring to static conditions calculated at the half of the screw length. In conditions of vibrations or in presence of dynamic loads these values should be reduced. For further information consult our technical office. We cannot accept responsibility for mounts that have been tampered or modified

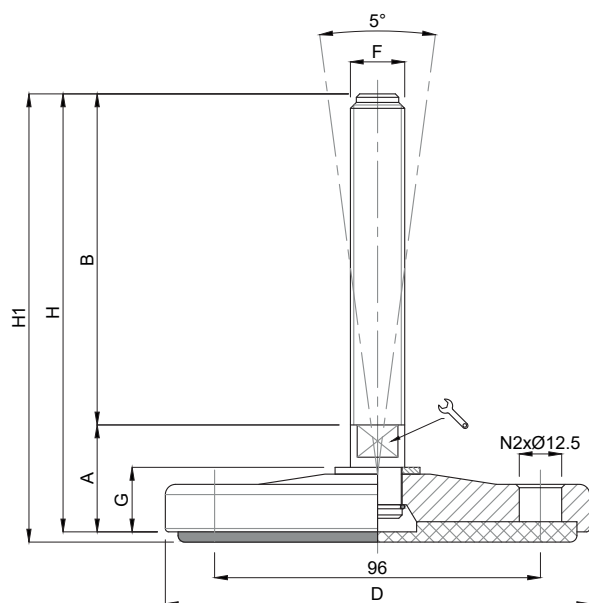

- Fornito con tappo
- Provided with cap

CODICE - CODE		DESCRIZIONE description	DIMENSIONI PRINCIPALI MAIN DIMENSIONS								CARICO STATICO STATIC LOAD NEWTON
standard standard	antiscivolo antislip		A	B	D		F	G	H	H1	
15221	15221/G	M16x75	29	75	Ø 120	17	M16	16,5	104	107	40000
15222	15222/G	M16x100	29	100	Ø 120	17	M16	16,5	129	132	40000
15223	15223/G	M16x150	29	150	Ø 120	17	M16	16,5	179	182	40000
15224	15224/G	M20x75	29	75	Ø 120	17	M20	16,5	104	107	40000
15225	15225/G	M20x125	29	125	Ø 120	17	M20	16,5	154	157	40000
15226	15226/G	M20x175	29	175	Ø 120	17	M20	16,5	204	207	40000
15227	15227/G	M24x100	30	100	Ø 120	20	M24	16,5	130	133	45000
**	15228	15228/G	30	150	Ø 120	20	M24	16,5	180	183	45000
**	15229	15229/G	30	200	Ø 120	20	M24	16,5	230	233	45000
	15230	15230/G	30	125	Ø 120	26	M30	16,5	155	158	45000
**	15231	15231/G	30	175	Ø 120	26	M30	16,5	205	208	45000
**	15232	15232/G	30	225	Ø 120	26	M30	16,5	255	258	45000

\*\* Disponibile con Filettatura a passo fine. Aggiungere "/P2" al codice  
Available with Thin pitch thread. Please, add "/P2" to the code

• Materiale base: acciaio inox AISI 304 (a richiesta AISI 316) finitura: tornitura fine. A richiesta disponibile con gomma antiscivolo NBR 70 shore. Materiale stelo: acciaio inox AISI 304 (a richiesta AISI 316). Su richiesta l'elemento di livellamento viene fornito con dado in acciaio.

• I valori dei carichi sopra riportati sono calcolati in condizioni statiche alla metà della lunghezza dello stelo filettato. Qualora s'intendesse utilizzare i supporti in presenza di vibrazioni o carichi in movimento, tali valori dovranno essere adeguatamente ridotti. Per ulteriori chiarimenti consultare il nostro ufficio tecnico. Ogni nostra responsabilità decade in caso di manomissioni o modifiche dei componenti.

• Stainless steel base in 1.4301 (1.4401 on specific request). Turning surface finishing. Stainless steel screw in 1.4301 (1.4401 on specific request). The leveling element could be supplied, on request, with steel nut.

• Load values above mentioned have to be considered referring to static conditions calculated at the half of the screw length. In conditions of vibrations or in presence of dynamic loads these values should be reduced. For further information consult our technical office. We cannot accept responsibility for mounts that have been tampered or modified

**Caratteristiche: BASE DAL PIENO Ø 150 CON 2 FORI, STELO SNODATO 5°**  
**Features: SOLID BASE Ø 150 WITH 2 BORES, 5° ARTICULATED STEM**

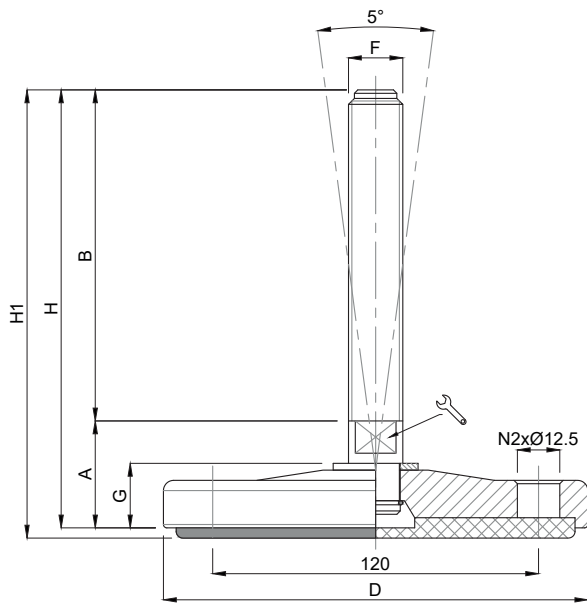

- Fornito con tappo
- Provided with cap

INOX

CODICE - CODE		DESCRIZIONE description	DIMENSIONI PRINCIPALI MAIN DIMENSIONS								CARICO STATICO STATIC LOAD NEWTON
standard standard	antiscivolo antislip		A	B	D		F	G	H	H1	
15233	15233/G	M20x75	29	75	ø 150	17	M20	16,5	104	107	50000
15234	15234/G	M20x125	29	125	ø 150	17	M20	16,5	154	157	50000
15235	15235/G	M20x175	29	175	ø 150	17	M20	16,5	204	207	50000
15236	15236/G	M24x100	30	100	ø 150	20	M24	16,5	130	133	55000
**	15237	15237/G	30	150	ø 150	20	M24	16,5	180	183	55000
**	15238	15238/G	30	200	ø 150	20	M24	16,5	230	233	55000
15239	15239/G	M30x125	30	125	ø 150	26	M30	16,5	155	158	55000
**	15240	15240/G	30	175	ø 150	26	M30	16,5	205	208	55000
**	15241	15241/G	30	225	ø 150	26	M30	16,5	255	258	55000

\*\* Disponibile con Filettatura a passo fine. Aggiungere "/P2" al codice  
 Available with Thin pitch thread. Please, add "/P2" to the code

• Materiale base: acciaio inox AISI 304 (a richiesta AISI 316) finitura: tornitura fine. A richiesta disponibile con gomma antiscivolo NBR 70 shore. Materiale stelo: acciaio inox AISI 304 (a richiesta AISI 316). Su richiesta l'elemento di livellamento viene fornito con dado in acciaio.

• I valori dei carichi sopra riportati sono calcolati in condizioni statiche alla metà della lunghezza dello stelo filettato. Qualora s'intendesse utilizzare i supporti in presenza di vibrazioni o carichi in movimento, tali valori dovranno essere adeguatamente ridotti. Per ulteriori chiarimenti consultare il nostro ufficio tecnico. Ogni nostra responsabilità decade in caso di manomissioni o modifiche dei componenti.

• Stainless steel base in 1.4301 (1.4401 on specific request). Turning surface finishing. Stainless steel screw in 1.4301 (1.4401 on specific request). The leveling element could be supplied, on request, with steel nut.

• Load values above mentioned have to be considered referring to static conditions calculated at the half of the screw length. In conditions of vibrations or in presence of dynamic loads these values should be reduced. For further information consult our technical office. We cannot accept responsibility for mounts that have been tampered or modified



## LINEA CARICHI PESANTI

### HEAVY DUTY LINE

- Materiale base: acciaio inox AISI 304 (a richiesta AISI 316). A richiesta disponibile con gomma antiscivolo NBR 70 shore (codice standard = senza gomma). Materiale stelo: acciaio inox AISI 304 (a richiesta AISI 316). Su richiesta l'elemento di livellamento viene fornito con dado in acciaio.
- I valori dei carichi sopra riportati sono calcolati in condizioni statiche alla metà della lunghezza dello stelo filettato. Qualora s'intendesse utilizzare i supporti in presenza di vibrazioni o carichi in movimento, tali valori dovranno essere adeguatamente ridotti. Per ulteriori chiarimenti consultare il nostro ufficio tecnico. Ogni nostra responsabilità decade in caso di manomissioni o modifiche dei componenti.
- *Stainless steel base in 1.4301 (1.4401 on specific request). On request anti-slip rubber 70 shore. Stainless steel screw in 1.4301 (1.4401 on specific request). The leveling element could be supplied, on request, with steel nut.*
- *Load values above mentioned have to be considered referring to static conditions calculated at the half of the screw length. In conditions of vibrations or in presence of dynamic loads these values should be reduced. For further information consult our technical office. We cannot accept responsibility for mounts that have been tampered or modified*

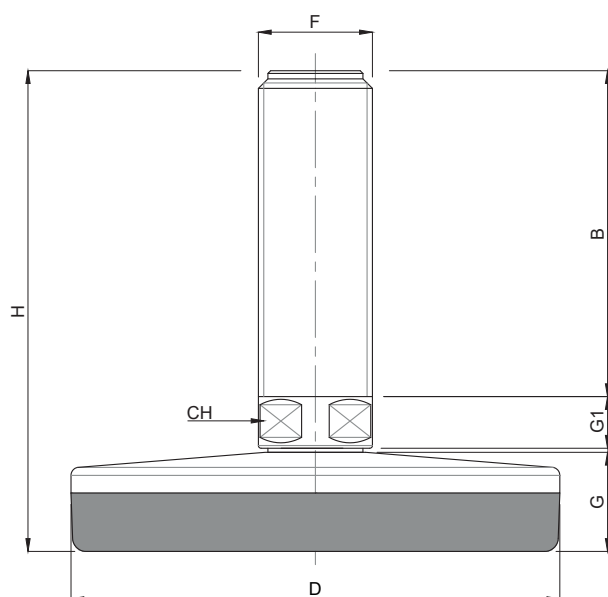

CODICE - CODE	descrizione description	DIMENSIONI PRINCIPALI - MAIN DIMENSIONS							CARICO STATICO STATIC LOAD NEWTON
		B	D	CH	F	G	G1	H	
15109-150VM30	M30X120	120	Ø150	26	M30	36.5	19	177	25000
15110-180VM42	M42X120	120	Ø180	36	M42	36.7	19	177	40000

**Applicazioni:** Questa tipologia è particolarmente adatta a risolvere problemi di vibrazioni nel processo di lavorazione garantendo la massima igiene.

**Application:** This model is particularly suitable to solve vibrations problems during the machine processing, always granting the highest hygiene conditions.

- Materiale base e stelo: acciaio inox AISI 304 (316 a richiesta)  
Gomma: EPDM 80 shore vulcanizzata

- I valori dei carichi sopra riportati sono calcolati in condizioni statiche alla metà della lunghezza dello stelo filettato. Qualora s'intendesse utilizzare i supporti in presenza di vibrazioni o carichi in movimento, tali valori dovranno essere adeguatamente ridotti. Per ulteriori chiarimenti consultare il nostro ufficio tecnico. Ogni nostra responsabilità decade in caso di manomissioni o modifiche dei componenti.

- Screw and base material: stainless steel 14301 (on request 14401)  
Pad: EPDM 80 shore

- Load values above mentioned have to be considered referring to static conditions calculated at the half of the screw length. In conditions of vibrations or in presence of dynamic loads these values should be reduced. For further information consult our technical office. We cannot accept responsibility for mounts that have been tampered or modified

Caratteristiche: BASE DAL PIENO Ø 30, STELO SNODATO 30°

Features: SOLID BASE Ø 30, 30° ARTICULATED STEM

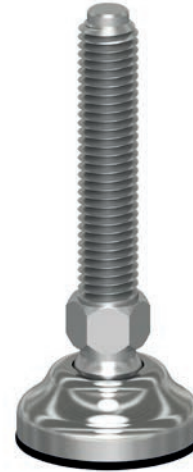
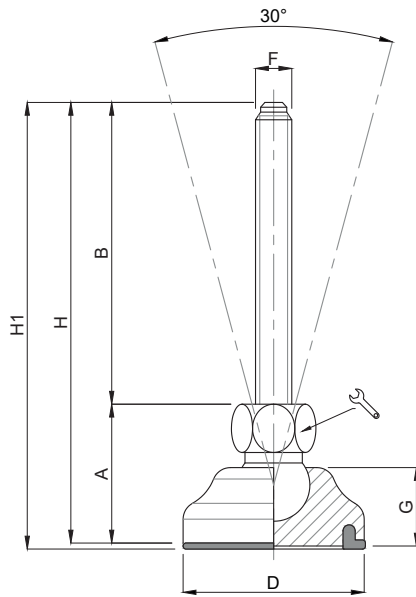

CODICE - CODE		descrizione description	DIMENSIONI PRINCIPALI - MAIN DIMENSIONS								CARICO STATICO STATIC LOAD NEWTON
standard standard	antiscivolo antislip		A	B	D		F	G	H	H1	
10438/6D30	10439/6D30	M6X25	23,5	25	Ø30	12	M6	13	48,5	49	5000
10440/6D30	10441/6D30	M6X50	23,5	50	Ø30	12	M6	13	73,5	74	5000
10442/6D30	10443/6D30	M6X75	23,5	75	Ø30	12	M6	13	98,5	99	5000
10438/D30	10439/D30	M8X25	23,5	25	Ø30	12	M8	13	48,5	49	8000
10440/D30	10441/D30	M8X50	23,5	50	Ø30	12	M8	13	73,5	74	8000
10442/D30	10443/D30	M8X75	23,5	75	Ø30	12	M8	13	98,5	99	8000
10446/D30	10447/D30	M8X100	23,5	100	Ø30	12	M8	13	123,5	124	8000
10448/D30	10449/D30	M10X25	23,5	25	Ø30	12	M10	13	48,5	49	10000
10450/D30	10451/D30	M10X50	23,5	50	Ø30	12	M10	13	73,5	74	10000
10452/D30	10453/D30	M10X75	23,5	75	Ø30	12	M10	13	98,5	99	10000
10454/D30	10455/D30	M10X100	23,5	100	Ø30	12	M10	13	123,5	124	10000
10456/D30	10457/D30	M10X125	23,5	125	Ø30	12	M10	13	148,5	149	10000
10448/12D30	10449/12D30	M12X25	23,5	25	Ø30	12	M12	13	48,5	49	10000
10450/12D30	10451/12D30	M12X50	23,5	50	Ø30	12	M12	13	73,5	74	10000
10452/12D30	10453/12D30	M12X75	23,5	75	Ø30	12	M12	13	98,5	99	10000
10454/12D30	10455/12D30	M12X100	23,5	100	Ø30	12	M12	13	123,5	124	10000
10456/12D30	10457/12D30	M12X125	23,5	125	Ø30	12	M12	13	148,5	149	10000
10456/12X150D30	10457/12X150D30	M12X150	23,5	150	Ø30	12	M12	13	173,5	174	10000

• Materiale base: acciaio inox AISI 304 (a richiesta AISI 316). A richiesta disponibile con gomma antiscivolo NBR 70 shore (codice standard = senza gomma). Materiale stelo: acciaio inox AISI 304 (a richiesta AISI 316). Su richiesta l'elemento di livellamento viene fornito con dado in acciaio.

• I valori dei carichi sopra riportati sono calcolati in condizioni statiche alla metà della lunghezza dello stelo filettato. Qualora s'intendesse utilizzare i supporti in presenza di vibrazioni o carichi in movimento, tali valori dovranno essere adeguatamente ridotti. Per ulteriori chiarimenti consultare il nostro ufficio tecnico. Ogni nostra responsabilità decade in caso di manomissioni o modifiche dei componenti.

• *Stainless steel base in 1.4301 (1.4401 on specific request). On request non-skid plate in NBR rubber 70 shore is available (Standard code = without rubber). Stainless steel screw in 1.4301 (1.4401 on specific request). The leveling element could be supplied, on request, with steel nut.*

• *Load values above mentioned have to be considered referring to static conditions calculated at the half of the screw length. In conditions of vibrations or in presence of dynamic loads these values should be reduced. For further information consult our technical office. We cannot accept responsibility for mounts that have been tampered or modified*

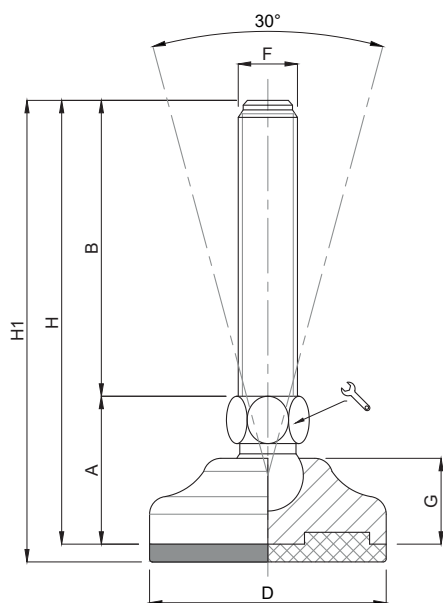

CODICE - CODE		descrizione description	DIMENSIONI PRINCIPALI - MAIN DIMENSIONS								CARICO STATICO STATIC LOAD NEWTON
standard standard	antiscivolo antislip		A	B	D		F	G	H	H1	
10438	10439	M8X25	25	25	Ø 40	12	M8	14,5	50	53	10000
10440	10441	M8X50	25	50	Ø 40	12	M8	14,5	75	78	10000
10442	10443	M8X75	25	75	Ø 40	12	M8	14,5	100	103	10000
10446	10447	M8X100	25	100	Ø 40	12	M8	14,5	125	128	10000
10448	10449	M10X25	25	25	Ø 40	12	M10	14,5	50	53	10000
10450	10451	M10X50	25	50	Ø 40	12	M10	14,5	75	78	10000
10452	10453	M10X75	25	75	Ø 40	12	M10	14,5	100	103	10000
10454	10455	M10X100	25	100	Ø 40	12	M10	14,5	125	128	10000
10456	10457	M10X125	25	125	Ø 40	12	M10	14,5	150	153	10000
10448/12	10449/12	M12X25	25	25	Ø 40	12	M12	14,5	50	53	10000
10450/12	10451/12	M12X50	25	50	Ø 40	12	M12	14,5	75	78	10000
10452/12	10453/12	M12X75	25	75	Ø 40	12	M12	14,5	100	103	10000
10454/12	10455/12	M12X100	25	100	Ø 40	12	M12	14,5	125	128	10000
10456/12	10457/12	M12X125	25	125	Ø 40	12	M12	14,5	150	153	10000
10456/12x150	10457/12x150	M12X150	25	150	Ø 40	12	M12	14,5	175	178	10000

• Materiale base: acciaio inox AISI 304 (a richiesta AISI 316). A richiesta disponibile con gomma antiscivolo NBR 70 shore (codice standard = senza gomma). Materiale stelo: acciaio inox AISI 304 (a richiesta AISI 316). Su richiesta l'elemento di livellamento viene fornito con dado in acciaio.

• I valori dei carichi sopra riportati sono calcolati in condizioni statiche alla metà della lunghezza dello stelo filettato. Qualora s'intendesse utilizzare i supporti in presenza di vibrazioni o carichi in movimento, tali valori dovranno essere adeguatamente ridotti. Per ulteriori chiarimenti consultare il nostro ufficio tecnico. Ogni nostra responsabilità decade in caso di manomissioni o modifiche dei componenti.

• *Stainless steel base in 1.4301 (1.4401 on specific request). On request non-skid plate in NBR rubber 70 shore is available (Standard code = without rubber). Stainless steel screw in 1.4301 (1.4401 on specific request). The leveling element could be supplied, on request, with steel nut.*

• *Load values above mentioned have to be considered referring to static conditions calculated at the half of the screw length. In conditions of vibrations or in presence of dynamic loads these values should be reduced. For further information consult our technical office. We cannot accept responsibility for mounts that have been tampered or modified*

Caratteristiche: BASE DAL PIENO Ø 50, STELO SNODATO 30°

Features: SOLID BASE Ø 50, 30° ARTICULATED STEM

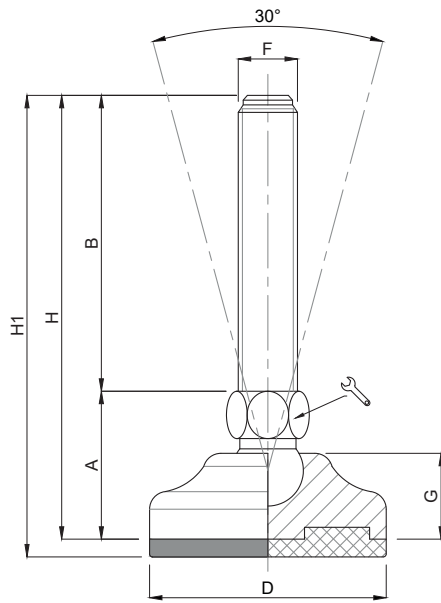

CODICE - CODE		descrizione description	DIMENSIONI PRINCIPALI - MAIN DIMENSIONS								CARICO STATICO STATIC LOAD NEWTON
standard standard	antiscivolo antislip		A	B	D		F	G	H	H1	
10458	10459	M10X25	28	25	Ø 50	14	M10	16	53	56	15000
10460	10461	M10X50	28	50	Ø 50	14	M10	16	78	81	15000
10462	10463	M10X75	28	75	Ø 50	14	M10	16	103	106	15000
10464	10465	M10X100	28	100	Ø 50	14	M10	16	128	131	15000
10466	10467	M10X125	28	125	Ø 50	14	M10	16	153	156	15000
10468	10469	M12X25	28	25	Ø 50	14	M12	16	53	56	15000
10470	10471	M12X50	28	50	Ø 50	14	M12	16	78	81	15000
10472	10473	M12X75	28	75	Ø 50	14	M12	16	103	106	15000
10474	10475	M12X100	28	100	Ø 50	14	M12	16	128	131	15000
10476	10477	M12X125	28	125	Ø 50	14	M12	16	153	156	15000
10476/150	10477/150	M12X150	28	150	Ø 50	14	M12	16	178	181	15000
10478	10479	M14X25	28	25	Ø 50	14	M14	16	53	56	15000
10480	10481	M14X50	28	50	Ø 50	14	M14	16	78	81	15000
10482	10483	M14X75	28	75	Ø 50	14	M14	16	103	106	15000
10484	10485	M14X100	28	100	Ø 50	14	M14	16	128	131	15000
10486	10487	M14X125	28	125	Ø 50	14	M14	16	153	156	15000









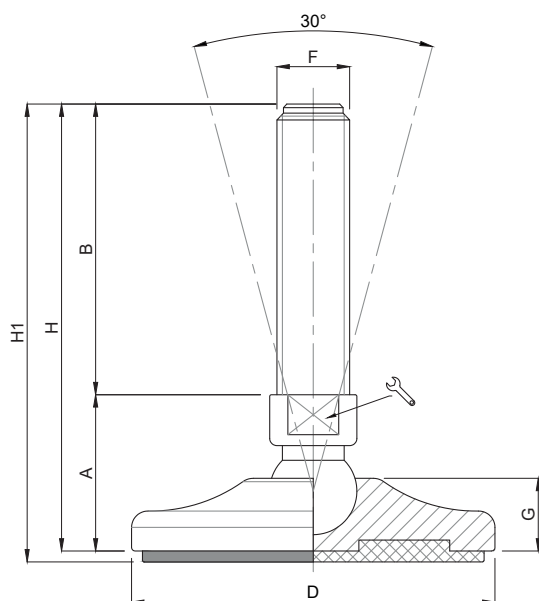



• Materiale base: acciaio inox AISI 304 (a richiesta AISI 316). A richiesta disponibile con gomma antiscivolo NBR 70 shore (codice standard = senza gomma). Materiale stelo: acciaio inox AISI 304 (a richiesta AISI 316). Su richiesta l'elemento di livellamento viene fornito con dado in acciaio.

• I valori dei carichi sopra riportati sono calcolati in condizioni statiche alla metà della lunghezza dello stelo filettato. Qualora s'intendesse utilizzare i supporti in presenza di vibrazioni o carichi in movimento, tali valori dovranno essere adeguatamente ridotti. Per ulteriori chiarimenti consultare il nostro ufficio tecnico. Ogni nostra responsabilità decade in caso di manomissioni o modifiche dei componenti.

• *Stainless steel base in 1.4301 (1.4401 on specific request). On request non-skid plate in NBR rubber 70 shore is available (Standard code = without rubber). Stainless steel screw in 1.4301 (1.4401 on specific request). The leveling element could be supplied, on request, with steel nut.*

• *Load values above mentioned have to be considered referring to static conditions calculated at the half of the screw length. In conditions of vibrations or in presence of dynamic loads these values should be reduced. For further information consult our technical office. We cannot accept responsibility for mounts that have been tampered or modified*



CODICE - CODE		descrizione description	DIMENSIONI PRINCIPALI - MAIN DIMENSIONS								CARICO STATICO STATIC LOAD NEWTON	
standard standard	antiscivolo antislip		A	B	D		F	G	H	H1		
10488	10489	M14X50	30	50	Ø 65	14		M14	17	80	83	20000
10490	10491	M14X75	30	75	Ø 65	14		M14	17	105	108	20000
10492	10493	M14X100	30	100	Ø 65	14		M14	17	130	133	20000
10494	10495	M14X125	30	125	Ø 65	14		M14	17	155	158	20000
10496	10497	M14X150	30	150	Ø 65	14		M14	17	180	183	20000
10500	10501	M16X50	34,5	50	Ø 65	13		M16	17	84,5	89,5	20000
10502	10503	M16X75	34,5	75	Ø 65	13		M16	17	109,5	112,5	20000
10504	10505	M16X100	34,5	100	Ø 65	13		M16	17	134,5	137,5	20000
10506	10507	M16X125	34,5	125	Ø 65	13		M16	17	159,5	162,5	20000
10508	10509	M16X150	34,5	150	Ø 65	13		M16	17	184,5	187,5	20000
10510	10511	M16X175	34,5	175	Ø 65	13		M16	17	209,5	212,5	20000

• Materiale base: acciaio inox AISI 304 (a richiesta AISI 316). A richiesta disponibile con gomma antiscivolo NBR 70 shore (codice standard = senza gomma). Materiale stelo: acciaio inox AISI 304 (a richiesta AISI 316). Su richiesta l'elemento di livellamento viene fornito con dado in acciaio.

• I valori dei carichi sopra riportati sono calcolati in condizioni statiche alla metà della lunghezza dello stelo filettato. Qualora s'intendesse utilizzare i supporti in presenza di vibrazioni o carichi in movimento, tali valori dovranno essere adeguatamente ridotti. Per ulteriori chiarimenti consultare il nostro ufficio tecnico. Ogni nostra responsabilità decade in caso di manomissioni o modifiche dei componenti.

• *Stainless steel base in 1.4301 (1.4401 on specific request). On request non-skid plate in NBR rubber 70 shore is available (Standard code = without rubber). Stainless steel screw in 1.4301 (1.4401 on specific request). The leveling element could be supplied, on request, with steel nut.*

• *Load values above mentioned have to be considered referring to static conditions calculated at the half of the screw length. In conditions of vibrations or in presence of dynamic loads these values should be reduced. For further information consult our technical office. We cannot accept responsibility for mounts that have been tampered or modified*

Caratteristiche: BASE DAL PIENO Ø 80, STELO SNODATO 30°

Features: SOLID BASE Ø 80, 30° ARTICULATED STEM

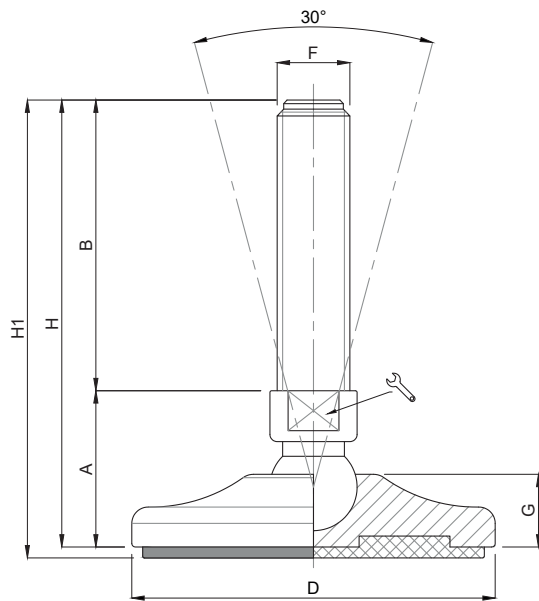

CODICE - CODE		descrizione description	DIMENSIONI PRINCIPALI - MAIN DIMENSIONS							CARICO STATICO STATIC LOAD NEWTON	
standard standard	antiscivolo antislip		A	B	D		F	G	H		H1
10514	10515	M16X50	36	50	Ø 80	13	M16	19,5	86	89	30000
10516	10517	M16X75	36	75	Ø 80	13	M16	19,5	111	114	30000
10518	10519	M16X100	36	100	Ø 80	13	M16	19,5	136	139	30000
10520	10521	M16X125	36	125	Ø 80	13	M16	19,5	159	163	30000
10522	10523	M16X150	36	150	Ø 80	13	M16	19,5	186	189	30000
10524	10525	M16X175	36	175	Ø 80	13	M16	19,5	211	214	30000
10526	10527	M16X200	36	200	Ø 80	13	M16	19,5	236	239	30000
10528	10529	M20X75	36	75	Ø 80	17	M20	19,5	111	114	30000
10530	10531	M20X100	36	100	Ø 80	17	M20	19,5	136	139	30000
10532	10533	M20X125	36	125	Ø 80	17	M20	19,5	161	164	30000
10534	10535	M20X150	36	150	Ø 80	17	M20	19,5	186	189	30000
10536	10537	M20X175	36	175	Ø 80	17	M20	19,5	211	214	30000
10538	10539	M20X200	36	200	Ø 80	17	M20	19,5	236	239	30000
10540	10541	M20X225	36	225	Ø 80	17	M20	19,5	261	264	30000

• Materiale base: acciaio inox AISI 304 (a richiesta AISI 316). A richiesta disponibile con gomma antiscivolo NBR 70 shore (codice standard = senza gomma). Materiale stelo: acciaio inox AISI 304 (a richiesta AISI 316). Su richiesta l'elemento di livellamento viene fornito con dado in acciaio.

• I valori dei carichi sopra riportati sono calcolati in condizioni statiche alla metà della lunghezza dello stelo filettato. Qualora s'intendesse utilizzare i supporti in presenza di vibrazioni o carichi in movimento, tali valori dovranno essere adeguatamente ridotti. Per ulteriori chiarimenti consultare il nostro ufficio tecnico. Ogni nostra responsabilità decade in caso di manomissioni o modifiche dei componenti.

• *Stainless steel base in 1.4301 (1.4401 on specific request). On request non-skid plate in NBR rubber 70 shore is available (Standard code = without rubber). Stainless steel screw in 1.4301 (1.4401 on specific request). The leveling element could be supplied, on request, with steel nut.*

• *Load values above mentioned have to be considered referring to static conditions calculated at the half of the screw length. In conditions of vibrations or in presence of dynamic loads these values should be reduced. For further information consult our technical office. We cannot accept responsibility for mounts that have been tampered or modified*

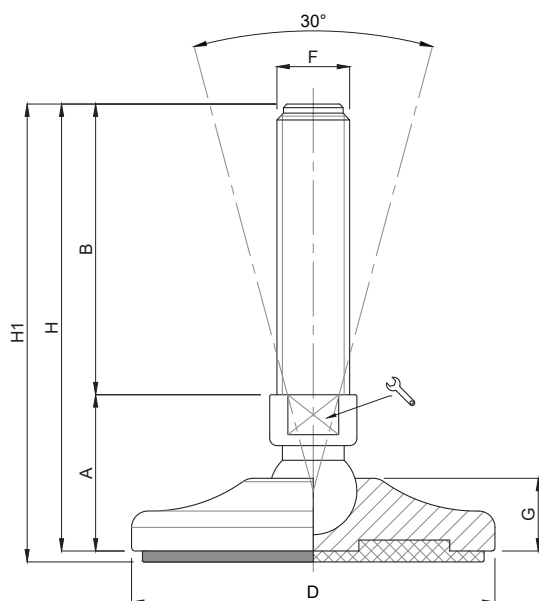

CODICE - CODE		descrizione description	DIMENSIONI PRINCIPALI - MAIN DIMENSIONS								CARICO STATICO STATIC LOAD NEWTON
standard standard	antiscivolo antislip		A	B	D		F	G	H	H1	
10542	10543	M16X50	43	50	Ø 100	20	M16	20	93	96	35000
10544	10545	M16X75	43	75	Ø 100	20	M16	20	118	121	35000
10546	10547	M16X100	43	100	Ø 100	20	M16	20	143	146	35000
10548	10549	M16X125	43	125	Ø 100	20	M16	20	168	171	35000
10550	10551	M16X150	43	150	Ø 100	20	M16	20	193	196	35000
10552	10553	M16X175	43	175	Ø 100	20	M16	20	218	221	35000
10554	10555	M16X200	43	200	Ø 100	20	M16	20	243	246	35000
10560	10561	M20X75	43	75	Ø 100	20	M20	20	118	121	45000
10562	10563	M20X100	43	100	Ø 100	20	M20	20	143	146	45000
10564	10565	M20X125	43	125	Ø 100	20	M20	20	168	171	45000
10566	10567	M20X150	43	150	Ø 100	20	M20	20	193	196	45000
10568	10569	M20X175	43	175	Ø 100	20	M20	20	218	221	45000
10570	10571	M20X200	43	200	Ø 100	20	M20	20	243	246	45000
10572	10573	M20X225	43	225	Ø 100	20	M20	20	268	271	45000
10574	10575	M20X250	43	250	Ø 100	20	M20	20	293	296	45000
10578	10579	M24X75	44	75	Ø 100	20	M24	20	119	122	55000
10580	10581	M24X100	44	100	Ø 100	20	M24	20	144	147	55000
10582	10583	M24X125	44	125	Ø 100	20	M24	20	169	172	55000
*	10584	10585	44	150	Ø 100	20	M24	20	199	202	55000
	10586	10587	44	175	Ø 100	20	M24	20	219	222	55000
*	10588	10589	44	200	Ø 100	20	M24	20	244	247	55000
	10590	10591	44	225	Ø 100	20	M24	20	269	272	55000
	10592	10593	44	250	Ø 100	20	M24	20	294	297	55000

\* Disponibile con Filettatura a passo fine. Aggiungere "/P2" al codice  
Available with Thin pitch thread. Please, add "/P2" to the code

• Materiale base: acciaio inox AISI 304 (a richiesta AISI 316). A richiesta disponibile con gomma antiscivolo NBR 70 shore (codice standard = senza gomma). Materiale stelo: acciaio inox AISI 304 (a richiesta AISI 316). Su richiesta l'elemento di livellamento viene fornito con dado in acciaio.

• I valori dei carichi sopra riportati sono calcolati in condizioni statiche alla metà della lunghezza dello stelo filettato. Qualora s'intendesse utilizzare i supporti in presenza di vibrazioni o carichi in movimento, tali valori dovranno essere adeguatamente ridotti. Per ulteriori chiarimenti consultare il nostro ufficio tecnico. Ogni nostra responsabilità decade in caso di manomissioni o modifiche dei componenti.

• Stainless steel base in 1.4301 (1.4401 on specific request). On request non-skid plate in NBR rubber 70 shore is available (Standard code = without rubber). Stainless steel screw in 1.4301 (1.4401 on specific request). The leveling element could be supplied, on request, with steel nut.

• Load values above mentioned have to be considered referring to static conditions calculated at the half of the screw length. In conditions of vibrations or in presence of dynamic loads these values should be reduced. For further information consult our technical office. We cannot accept responsibility for mounts that have been tampered or modified

Caratteristiche: BASE DAL PIENO Ø 120, STELO SNODATO 30°

Features: SOLID BASE Ø 120, 30° ARTICULATED STEM

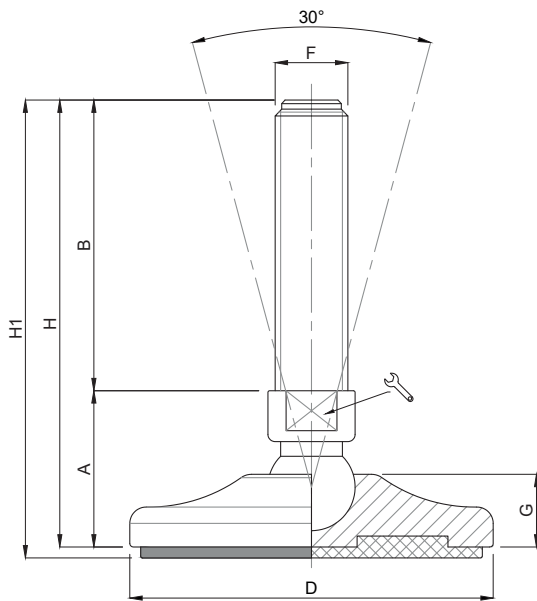

CODICE - CODE		descrizione description	DIMENSIONI PRINCIPALI - MAIN DIMENSIONS								CARICO STATICO STATIC LOAD NEWTON
standard standard	antiscivolo antislip		A	B	D		F	G	H	H1	
10594	10595	M16X50	46	50	Ø 120	20	M16	23	96	99	35000
10596	10597	M16X75	46	75	Ø 120	20	M16	23	121	124	35000
10598	10599	M16X100	46	100	Ø 120	20	M16	23	146	149	35000
10600	10601	M16X125	46	125	Ø 120	20	M16	23	171	174	35000
10602	10603	M16X150	46	150	Ø 120	20	M16	23	196	199	35000
10604	10605	M16X175	46	175	Ø 120	20	M16	23	221	224	35000
10606	10607	M16X200	46	200	Ø 120	20	M16	23	246	249	35000
10612	10613	M20X75	46	75	Ø 120	20	M20	23	121	124	45000
10614	10615	M20X100	46	100	Ø 120	20	M20	23	146	149	45000
10616	10617	M20X125	46	125	Ø 120	20	M20	23	171	174	45000
10618	10619	M20X150	46	150	Ø 120	20	M20	23	196	199	45000
10620	10621	M20X175	46	175	Ø 120	20	M20	23	221	224	45000
10622	10623	M20X200	46	200	Ø 120	20	M20	23	246	249	45000
10624	10625	M20X225	46	225	Ø 120	20	M20	23	271	274	45000
10626	10627	M20X250	46	250	Ø 120	20	M20	23	296	299	45000

- Materiale base: acciaio inox AISI 304 (a richiesta AISI 316). A richiesta disponibile con gomma antiscivolo NBR 70 shore (codice standard = senza gomma). Materiale stelo: acciaio inox AISI 304 (a richiesta AISI 316). Su richiesta l'elemento di livellamento viene fornito con dado in acciaio.
- I valori dei carichi sopra riportati sono calcolati in condizioni statiche alla metà della lunghezza dello stelo filettato. Qualora s'intendesse utilizzare i supporti in presenza di vibrazioni o carichi in movimento, tali valori dovranno essere adeguatamente ridotti. Per ulteriori chiarimenti consultare il nostro ufficio tecnico. Ogni nostra responsabilità decade in caso di manomissioni o modifiche dei componenti.
- *Stainless steel base in 1.4301 (1.4401 on specific request). On request non-skid plate in NBR rubber 70 shore is available (Standard code = without rubber). Stainless steel screw in 1.4301 (1.4401 on specific request). The leveling element could be supplied, on request, with steel nut.*
- *Load values above mentioned have to be considered referring to static conditions calculated at the half of the screw length. In conditions of vibrations or in presence of dynamic loads these values should be reduced. For further information consult our technical office. We cannot accept responsibility for mounts that have been tampered or modified*

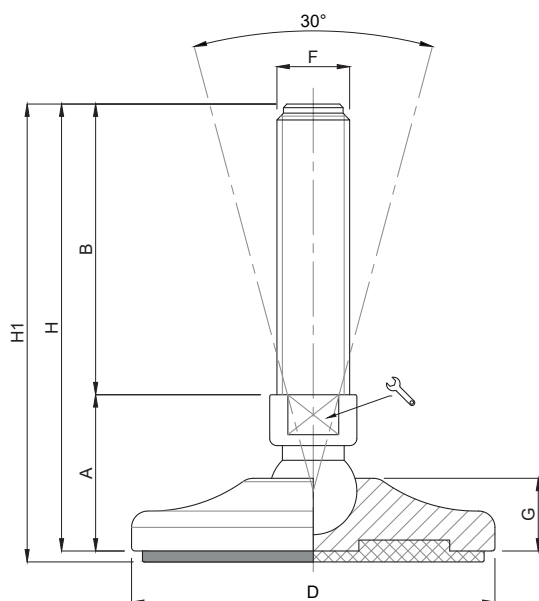

CODICE - CODE		descrizione description	DIMENSIONI PRINCIPALI - MAIN DIMENSIONS								CARICO STATICO STATIC LOAD NEWTON	
standard standard	antiscivolo antislip		A	B	D		F	G	H	H1		
10630	10631	M24X75	47	75	Ø 120	20	M24	23	122	125	55000	
10632	10633	M24X100	47	100	Ø 120	20	M24	23	147	150	55000	
10634	10635	M24X125	47	125	Ø 120	20	M24	23	172	175	55000	
*	10636	10637	M24X150	47	150	Ø 120	20	M24	23	197	200	55000
	10638	10639	M24X175	47	175	Ø 120	20	M24	23	222	225	55000
*	10640	10641	M24X200	47	200	Ø 120	20	M24	23	247	250	55000
	10642	10643	M24X225	47	225	Ø 120	20	M24	23	272	275	55000
	10644	10645	M24X250	47	250	Ø 120	20	M24	23	297	300	55000
	10646	10647	M30X100	47	100	Ø 120	26	M30	23	147	150	65000
	10648	10649	M30X125	47	125	Ø 120	26	M30	23	172	175	65000
*	10650	10651	M30X150	47	150	Ø 120	26	M30	23	197	200	65000
	10652	10653	M30X175	47	175	Ø 120	26	M30	23	222	225	65000
*	10654	10655	M30X200	47	200	Ø 120	26	M30	23	247	250	65000
	10656	10657	M30X225	47	225	Ø 120	26	M30	23	272	275	65000
	10658	10659	M30X250	47	250	Ø 120	26	M30	23	297	300	65000

\* Disponibile con Filettatura a passo fine. Aggiungere "/IP2" al codice  
Available with Thin pitch thread. Please, add "/IP2" to the code

- Materiale base: acciaio inox AISI 304 (a richiesta AISI 316). A richiesta disponibile con gomma antiscivolo NBR 70 shore (codice standard = senza gomma). Materiale stelo: acciaio inox AISI 304 (a richiesta AISI 316). Su richiesta l'elemento di livellamento viene fornito con dado in acciaio.
- I valori dei carichi sopra riportati sono calcolati in condizioni statiche alla metà della lunghezza dello stelo filettato. Qualora s'intendesse utilizzare i supporti in presenza di vibrazioni o carichi in movimento, tali valori dovranno essere adeguatamente ridotti. Per ulteriori chiarimenti consultare il nostro ufficio tecnico. Ogni nostra responsabilità decade in caso di manomissioni o modifiche dei componenti.
- Stainless steel base in 1.4301 (1.4401 on specific request). On request non-skid plate in NBR rubber 70 shore is available (Standard code = without rubber). Stainless steel screw in 1.4301 (1.4401 on specific request). The leveling element could be supplied, on request, with steel nut.
- Load values above mentioned have to be considered referring to static conditions calculated at the half of the screw length. In conditions of vibrations or in presence of dynamic loads these values should be reduced. For further information consult our technical office. We cannot accept responsibility for mounts that have been tampered or modified

Caratteristiche: BASE DAL PIENO Ø 140, STELO SNODATO 30°

Features: SOLID BASE Ø 140, 30° ARTICULATED STEM

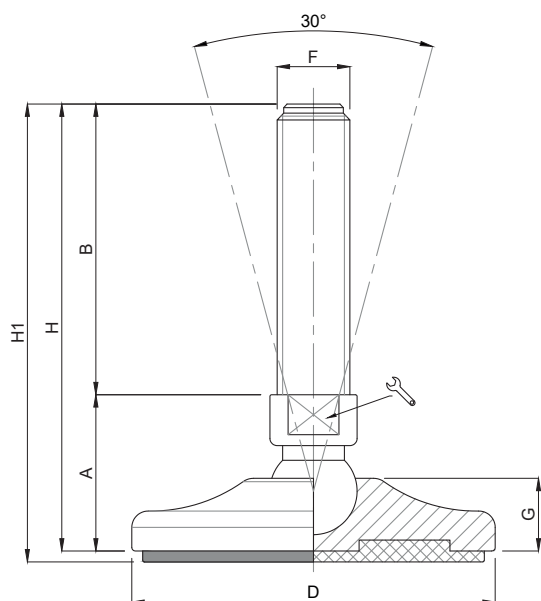

CODICE - CODE		descrizione description	DIMENSIONI PRINCIPALI - MAIN DIMENSIONS								CARICO STATICO STATIC LOAD NEWTON
standard standard	antiscivolo antislip		A	B	D		F	G	H	H1	
10884	10885	M20X75	49	75	Ø 140	20	M20	26	124	127	50000
10886	10887	M20X100	49	100	Ø 140	20	M20	26	149	152	50000
10888	10889	M20X125	49	125	Ø 140	20	M20	26	174	177	50000
10890	10891	M20X150	49	150	Ø 140	20	M20	26	199	202	50000
10892	10893	M20X175	49	175	Ø 140	20	M20	26	224	227	50000
10894	10895	M20X200	49	200	Ø 140	20	M20	26	249	252	50000
10904	10905	M24X75	49	75	Ø 140	20	M24	26	124	127	60000
10906	10907	M24X100	49	100	Ø 140	20	M24	26	149	152	60000
10908	10909	M24X125	49	125	Ø 140	20	M24	26	174	177	60000
* 10910	10911	M24X150	49	150	Ø 140	20	M24	26	199	202	60000
* 10912	10913	M24X175	49	175	Ø 140	20	M24	26	224	227	60000
* 10914	10915	M24X200	49	200	Ø 140	20	M24	26	249	252	60000
10920	10921	M30X100	49	100	Ø 140	26	M30	26	149	152	70000
10922	10923	M30X125	49	125	Ø 140	26	M30	26	174	177	70000
* 10924	10925	M30X150	49	150	Ø 140	26	M30	26	199	202	70000
10926	10927	M30X175	49	175	Ø 140	26	M30	26	224	227	70000
* 10928	10929	M30X200	49	200	Ø 140	26	M30	26	249	252	70000
10930	10931	M30X225	49	225	Ø 140	26	M30	26	274	277	70000
10932	10933	M30X250	49	250	Ø 140	26	M30	26	299	302	70000

\* Disponibile con Filettatura a passo fine. Aggiungere "/P2" al codice  
Available with Thin pitch thread. Please, add "/P2" to the code

- Materiale base: acciaio inox AISI 304 (a richiesta AISI 316). A richiesta disponibile con gomma antiscivolo NBR 70 shore (codice standard = senza gomma). Materiale stelo: acciaio inox AISI 304 (a richiesta AISI 316). Su richiesta l'elemento di livellamento viene fornito con dado in acciaio.
- I valori dei carichi sopra riportati sono calcolati in condizioni statiche alla metà della lunghezza dello stelo filettato. Qualora s'intendesse utilizzare i supporti in presenza di vibrazioni o carichi in movimento, tali valori dovranno essere adeguatamente ridotti. Per ulteriori chiarimenti consultare il nostro ufficio tecnico. Ogni nostra responsabilità decade in caso di manomissioni o modifiche dei componenti.
- Stainless steel base in 1.4301 (1.4401 on specific request). On request non-skid plate in NBR rubber 70 shore is available (Standard code = without rubber). Stainless steel screw in 1.4301 (1.4401 on specific request). The leveling element could be supplied, on request, with steel nut.
- Load values above mentioned have to be considered referring to static conditions calculated at the half of the screw length. In conditions of vibrations or in presence of dynamic loads these values should be reduced. For further information consult our technical office. We cannot accept responsibility for mounts that have been tampered or modified

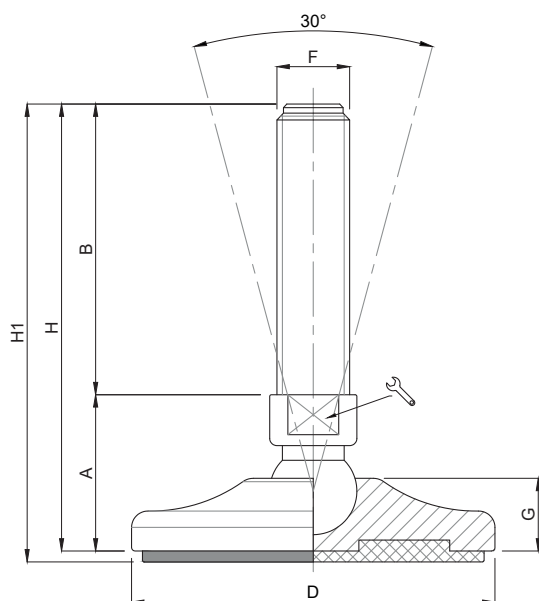

CODICE - CODE		descrizione description	DIMENSIONI PRINCIPALI - MAIN DIMENSIONS								CARICO STATICO STATIC LOAD NEWTON
standard standard	antiscivolo antislip		A	B	D		F	G	H	H1	
10934	10935	M20X75	49	75	Ø 160	20	M20	26	124	127	50000
10936	10937	M20X100	49	100	Ø 160	20	M20	26	149	152	50000
10938	10939	M20X125	49	125	Ø 160	20	M20	26	174	177	50000
10940	10941	M20X150	49	150	Ø 160	20	M20	26	199	202	50000
10942	10943	M20X175	49	175	Ø 160	20	M20	26	224	227	50000
10944	10945	M20X200	49	200	Ø 160	20	M20	26	249	252	50000
10946	10947	M24X75	49	75	Ø 160	20	M24	26	124	127	60000
10948	10949	M24X100	49	100	Ø 160	20	M24	26	149	152	60000
10950	10951	M24X125	49	125	Ø 160	20	M24	26	174	177	60000
* 10952	10953	M24X150	49	150	Ø 160	20	M24	26	199	202	60000
* 10954	10955	M24X175	49	175	Ø 160	20	M24	26	224	227	60000
* 10956	10957	M24X200	49	200	Ø 160	20	M24	26	249	252	60000
10958	10959	M30X100	49	100	Ø 160	26	M30	26	149	152	70000
10960	10961	M30X125	49	125	Ø 160	26	M30	26	174	177	70000
* 10962	10963	M30X150	49	150	Ø 160	26	M30	26	199	202	70000
10964	10965	M30X175	49	175	Ø 160	26	M30	26	224	227	70000
* 10966	10967	M30X200	49	200	Ø 160	26	M30	26	249	252	70000
10968	10969	M30X225	49	225	Ø 160	26	M30	26	274	277	70000
10970	10971	M30X250	49	250	Ø 160	26	M30	26	299	302	70000
10972	10973	M36x150	51	150	Ø 160	32	M36	26	201	204	80000
10974	10975	M36x200	51	200	Ø 160	32	M36	26	251	254	80000

\* Disponibile con Filettatura a passo fine. Aggiungere "IP2" al codice  
Available with Thin pitch thread. Please, add "IP2" to the code

• Materiale base: acciaio inox AISI 304 (a richiesta AISI 316). A richiesta disponibile con gomma antiscivolo NBR 70 shore (codice standard = senza gomma). Materiale stelo: acciaio inox AISI 304 (a richiesta AISI 316). Su richiesta l'elemento di livellamento viene fornito con dado in acciaio.

• I valori dei carichi sopra riportati sono calcolati in condizioni statiche alla metà della lunghezza dello stelo filettato. Qualora s'intendesse utilizzare i supporti in presenza di vibrazioni o carichi in movimento, tali valori dovranno essere adeguatamente ridotti. Per ulteriori chiarimenti consultare il nostro ufficio tecnico. Ogni nostra responsabilità decade in caso di manomissioni o modifiche dei componenti.

• Stainless steel base in 1.4301 (1.4401 on specific request). On request non-skid plate in NBR rubber 70 shore is available (Standard code = without rubber). Stainless steel screw in 1.4301 (1.4401 on specific request). The leveling element could be supplied, on request, with steel nut.

• Load values above mentioned have to be considered referring to static conditions calculated at the half of the screw length. In conditions of vibrations or in presence of dynamic loads these values should be reduced. For further information consult our technical office. We cannot accept responsibility for mounts that have been tampered or modified

Caratteristiche: BASE DAL PIENO Ø 80, STELO SNODATO 10°

Features: SOLID BASE Ø 80, 10° ARTICULATED STEM

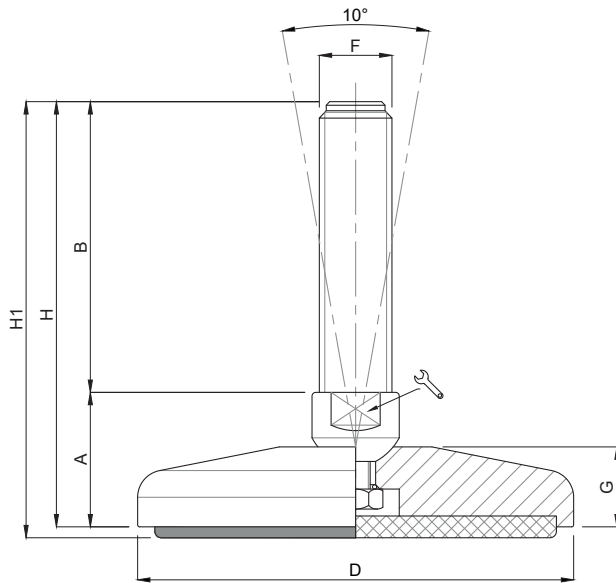

INOX

CODICE - CODE		descrizione description	DIMENSIONI PRINCIPALI - MAIN DIMENSIONS							CARICO STATICO STATIC LOAD NEWTON	
standard standard	antiscivolo antislip		A	B	D		F	G	H		H1
11334	11335	M16X100	33	100	Ø 80	20	M16	19	133	136	30000
11338	11339	M16X150	33	150	Ø 80	20	M16	19	183	186	30000
11342	11343	M16X200	33	200	Ø 80	20	M16	19	233	236	30000
11334/20	11335/20	M20X100	33	100	Ø 80	20	M20	19	133	136	35000
11338/20	11339/20	M20X150	33	150	Ø 80	20	M20	19	183	186	35000
11342/20	11343/20	M20X200	33	200	Ø 80	20	M20	19	233	236	35000
11344/20	11345/20	M20X225	33	225	Ø 80	20	M20	19	258	261	35000
11334/24	11335/24	M24X100	33	100	Ø 80	20	M24	19	133	136	40000
* 11338/24	11339/24	M24X150	33	150	Ø 80	20	M24	19	183	186	40000
* 11342/24	11343/24	M24X200	33	200	Ø 80	20	M24	19	233	236	40000
11344/24	11345/24	M24X225	33	225	Ø 80	20	M24	19	258	261	40000

\* Disponibile con Filettatura a passo fine. Aggiungere "/P2" al codice  
Available with Thin pitch thread. Please, add "/P2" to the code

• Materiale base: acciaio inox AISI 304 (a richiesta AISI 316). A richiesta disponibile con gomma antiscivolo NBR 70 shore (codice standard = senza gomma). Materiale stelo: acciaio inox AISI 304 (a richiesta AISI 316). Su richiesta l'elemento di livellamento viene fornito con dado in acciaio.

• I valori dei carichi sopra riportati sono calcolati in condizioni statiche alla metà della lunghezza dello stelo filettato. Qualora s'intendesse utilizzare i supporti in presenza di vibrazioni o carichi in movimento, tali valori dovranno essere adeguatamente ridotti. Per ulteriori chiarimenti consultare il nostro ufficio tecnico. Ogni nostra responsabilità decade in caso di manomissioni o modifiche dei componenti.

• Stainless steel base in 1.4301 (1.4401 on specific request). On request anti-slip rubber 70 shore. Stainless steel screw in 1.4301 (1.4401 on specific request). The leveling element could be supplied, on request, with steel nut.

• Load values above mentioned have to be considered referring to static conditions calculated at the half of the screw length. In conditions of vibrations or in presence of dynamic loads these values should be reduced. For further information consult our technical office. We cannot accept responsibility for mounts that have been tampered or modified

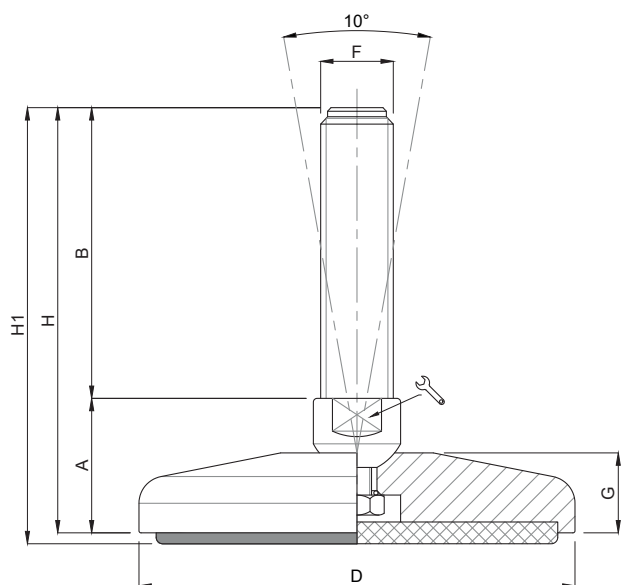

CODICE - CODE		descrizione description	DIMENSIONI PRINCIPALI - MAIN DIMENSIONS								CARICO STATICO STATIC LOAD NEWTON
standard standard	antiscivolo antislip		A	B	D		F	G	H	H1	
11382/16	11383/16	M16X100	34	100	Ø 100	20	M16	20	134	137	40000
11386/16	11387/16	M16X150	34	150	Ø 100	20	M16	20	184	187	40000
11390/16	11391/16	M16X200	34	200	Ø 100	20	M16	20	234	237	40000
11392/16	11393/16	M16X225	34	225	Ø 100	20	M16	20	259	262	40000
11382	11383	M20X100	34	100	Ø 100	20	M20	20	134	137	40000
11386	11387	M20X150	34	150	Ø 100	20	M20	20	184	187	40000
11390	11391	M20X200	34	200	Ø 100	20	M20	20	234	237	40000
11392	11393	M20X225	34	225	Ø 100	20	M20	20	259	262	40000
11382/24	11383/24	M24X100	34	100	Ø 100	20	M24	20	134	137	45000
* 11386/24	11387/24	M24X150	34	150	Ø 100	20	M24	20	184	187	45000
* 11390/24	11391/24	M24X200	34	200	Ø 100	20	M24	20	234	237	45000
11392/24	11393/24	M24X225	34	225	Ø 100	20	M24	20	259	262	45000
11382/30	11383/30	M30X100	40	100	Ø 100	26	M30	20	140	143	50000
* 11386/30	11387/30	M30X150	40	150	Ø 100	26	M30	20	190	193	50000
* 11390/30	11391/30	M30X200	40	200	Ø 100	26	M30	20	240	243	50000
11392/30	11393/30	M30X225	40	225	Ø 100	26	M30	20	265	268	50000

\* Disponibile con Filettatura a passo fine. Aggiungere "/P2" al codice  
Available with Thin pitch thread. Please, add "/P2" to the code

• Materiale base: acciaio inox AISI 304 (a richiesta AISI 316). A richiesta disponibile con gomma antiscivolo NBR 70 shore (codice standard = senza gomma). Materiale stelo: acciaio inox AISI 304 (a richiesta AISI 316). Su richiesta l'elemento di livellamento viene fornito con dado in acciaio.

• I valori dei carichi sopra riportati sono calcolati in condizioni statiche alla metà della lunghezza dello stelo filettato. Qualora s'intendesse utilizzare i supporti in presenza di vibrazioni o carichi in movimento, tali valori dovranno essere adeguatamente ridotti. Per ulteriori chiarimenti consultare il nostro ufficio tecnico. Ogni nostra responsabilità decade in caso di manomissioni o modifiche dei componenti.

• Stainless steel base in 1.4301 (1.4401 on specific request). On request anti-slip rubber 70 shore. Stainless steel screw in 1.4301 (1.4401 on specific request). The leveling element could be supplied, on request, with steel nut.

• Load values above mentioned have to be considered referring to static conditions calculated at the half of the screw length. In conditions of vibrations or in presence of dynamic loads these values should be reduced. For further information consult our technical office. We cannot accept responsibility for mounts that have been tampered or modified

Caratteristiche: BASE DAL PIENO Ø 120, STELO SNODATO 10°

Features: SOLID BASE Ø 120, 10° ARTICULATED STEM

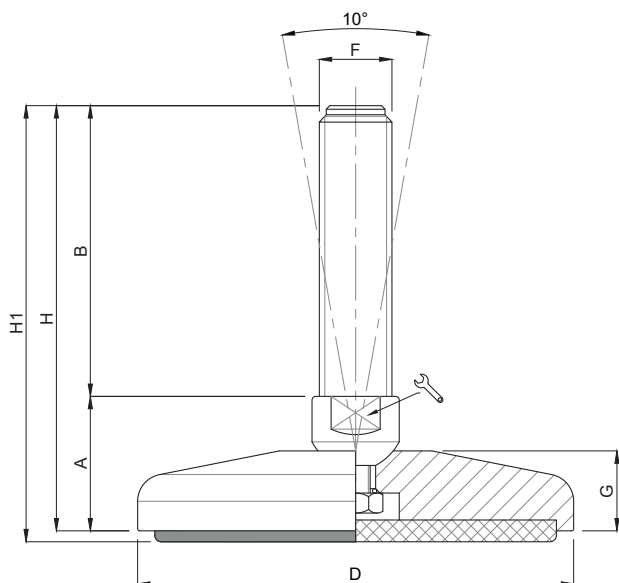

CODICE - CODE		descrizione description	DIMENSIONI PRINCIPALI - MAIN DIMENSIONS							CARICO STATICO STATIC LOAD NEWTON		
standard standard	antiscivolo antislip		A	B	D		F	G	H		H1	
11430	11431	M20X100	36	100	Ø 120	20	M20	22	136	139	45000	
11434	11435	M20X150	36	150	Ø 120	20	M20	22	186	189	45000	
11438	11439	M20X200	36	200	Ø 120	20	M20	22	236	239	45000	
11440	11441	M20X225	36	225	Ø 120	20	M20	22	261	264	45000	
	11430/24	11431/24	M24X100	36	100	Ø 120	20	M24	22	136	139	50000
*	11434/24	11435/24	M24X150	36	150	Ø 120	20	M24	22	186	189	50000
*	11438/24	11439/24	M24X200	36	200	Ø 120	20	M24	22	236	239	50000
	11440/24	11441/24	M24X225	36	225	Ø 120	20	M24	22	261	264	50000
	11430/30	11431/30	M30X100	42	100	Ø 120	26	M30	22	142	145	60000
*	11434/30	11435/30	M30X150	42	150	Ø 120	26	M30	22	192	195	60000
*	11438/30	11439/30	M30X200	42	200	Ø 120	26	M30	22	242	245	60000
	11440/30	11441/30	M30X225	42	225	Ø 120	26	M30	22	267	270	60000

\* Disponibile con Filettatura a passo fine. Aggiungere "/P2" al codice  
Available with Thin pitch thread. Please, add "/P2" to the code

• Materiale base: acciaio inox AISI 304 (a richiesta AISI 316). A richiesta disponibile con gomma antiscivolo NBR 70 shore (codice standard = senza gomma). Materiale stelo: acciaio inox AISI 304 (a richiesta AISI 316). Su richiesta l'elemento di livellamento viene fornito con dado in acciaio.

• I valori dei carichi sopra riportati sono calcolati in condizioni statiche alla metà della lunghezza dello stelo filettato. Qualora s'intendesse utilizzare i supporti in presenza di vibrazioni o carichi in movimento, tali valori dovranno essere adeguatamente ridotti. Per ulteriori chiarimenti consultare il nostro ufficio tecnico. Ogni nostra responsabilità decade in caso di manomissioni o modifiche dei componenti.

• Stainless steel base in 1.4301 (1.4401 on specific request). On request anti-slip rubber 70 shore. Stainless steel screw in 1.4301 (1.4401 on specific request). The leveling element could be supplied, on request, with steel nut.

• Load values above mentioned have to be considered referring to static conditions calculated at the half of the screw length. In conditions of vibrations or in presence of dynamic loads these values should be reduced. For further information consult our technical office. We cannot accept responsibility for mounts that have been tampered or modified

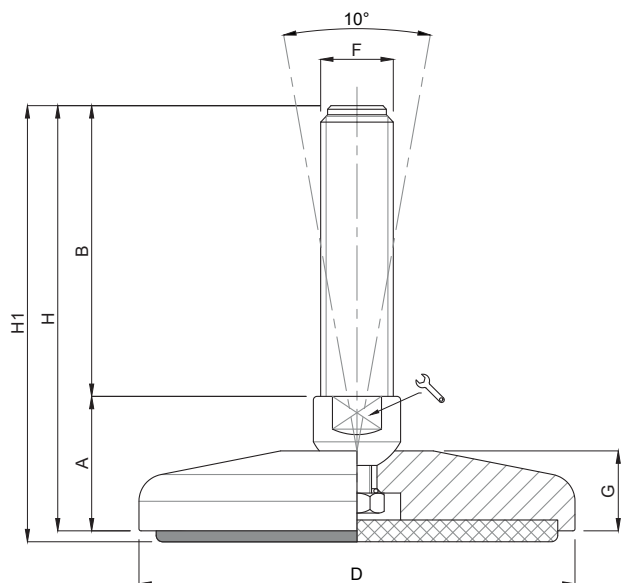

CODICE - CODE		descrizione description	DIMENSIONI PRINCIPALI - MAIN DIMENSIONS								CARICO STATICO STATIC LOAD NEWTON
standard standard	antiscivolo antislip		A	B	D		F	G	H	H1	
11478	11479	M20X100	37	100	Ø 159	20	M20	23	137	140	50000
11482	11483	M20X150	37	150	Ø 159	20	M20	23	187	190	50000
11486	11487	M20X200	37	200	Ø 159	20	M20	23	237	240	50000
11488	11489	M20X225	37	225	Ø 159	20	M20	23	262	265	50000
		M24X100	38	100	Ø 159	20	M24	23	138	141	60000
*		M24X150	38	150	Ø 159	20	M24	23	188	191	60000
*		M24X200	38	200	Ø 159	20	M24	23	238	241	60000
		M24X225	38	225	Ø 159	20	M24	23	263	266	60000
		M30X100	42	100	Ø 159	26	M30	23	142	145	70000
*		M30X150	42	150	Ø 159	26	M30	23	192	195	70000
*		M30X200	42	200	Ø 159	26	M30	23	242	245	70000
		M30X225	42	225	Ø 159	26	M30	23	267	270	70000

\* Disponibile con Filettatura a passo fine. Aggiungere "/P2" al codice  
Available with Thin pitch thread. Please, add "/P2" to the code

• Materiale base: acciaio inox AISI 304 (a richiesta AISI 316). A richiesta disponibile con gomma antiscivolo NBR 70 shore (codice standard = senza gomma). Materiale stelo: acciaio inox AISI 304 (a richiesta AISI 316). Su richiesta l'elemento di livellamento viene fornito con dado in acciaio.

• I valori dei carichi sopra riportati sono calcolati in condizioni statiche alla metà della lunghezza dello stelo filettato. Qualora s'intendesse utilizzare i supporti in presenza di vibrazioni o carichi in movimento, tali valori dovranno essere adeguatamente ridotti. Per ulteriori chiarimenti consultare il nostro ufficio tecnico. Ogni nostra responsabilità decade in caso di manomissioni o modifiche dei componenti.

• Stainless steel base in 1.4301 (1.4401 on specific request). On request anti-slip rubber 70 shore. Stainless steel screw in 1.4301 (1.4401 on specific request). The leveling element could be supplied, on request, with steel nut.

• Load values above mentioned have to be considered referring to static conditions calculated at the half of the screw length. In conditions of vibrations or in presence of dynamic loads these values should be reduced. For further information consult our technical office. We cannot accept responsibility for mounts that have been tampered or modified

## Piede Inox

## CARICHI PESANTI

Caratteristiche: BASE DAL PIENO Ø 80, STELO FISSO

Features: SOLID BASE Ø 80, FIX STEM

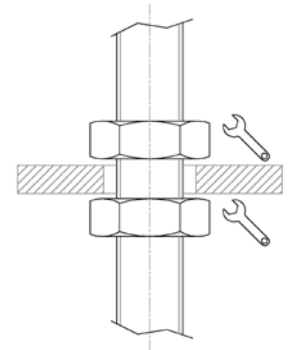
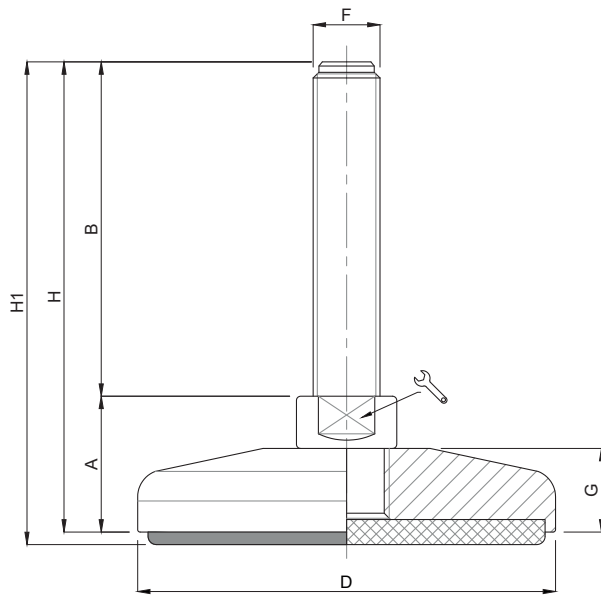

**ATTENZIONE:**  
Stelo non girevole.  
Utilizzare dado e controdado.  
Dado non fornito.

**ATTENTION:**  
Not pivoting stem.  
Use nut and locking nut.  
Nut not provided.

CODICE - CODE	descrizione	DIMENSIONI PRINCIPALI - MAIN DIMENSIONS							CARICO STATICO STATIC LOAD NEWTON
		A	B	D		F	G	H1	
11527	M16X100	31,5	100	Ø 80	17	M16	19	134,5	30000
11531	M16X150	31,5	150	Ø 80	17	M16	19	184,5	30000
11535	M16X200	31,5	200	Ø 80	17	M16	19	234,5	30000
11575	M20X100	31,5	100	Ø 80	20	M20	19	134,5	35000
11579	M20X150	31,5	150	Ø 80	20	M20	19	184,5	35000
11583	M20X200	31,5	200	Ø 80	20	M20	19	234,5	35000
11585	M20X225	31,5	225	Ø 80	20	M20	19	259,5	35000
11575/24	M24X100	33	100	Ø 80	20	M24	19	136	40000
* 11579/24	M24X150	33	150	Ø 80	20	M24	19	186	40000
* 11583/24	M24X200	33	200	Ø 80	20	M24	19	236	40000
11585/24	M24X225	33	225	Ø 80	20	M24	19	261	40000

\* Disponibile con Filettatura a passo fine. Aggiungere "/P2" al codice  
Available with Thin pitch thread. Please, add "/P2" to the code

• Materiale base: acciaio inox AISI 304 (a richiesta AISI 316). Elemento fornito con gomma antiscivolo NBR 70 shore. Materiale stelo: acciaio inox AISI 304 (a richiesta AISI 316). Su richiesta l'elemento di livellamento viene fornito con dado in acciaio.

• I valori dei carichi sopra riportati sono calcolati in condizioni statiche alla metà della lunghezza dello stelo filettato. Qualora s'intendesse utilizzare i supporti in presenza di vibrazioni o carichi in movimento, tali valori dovranno essere adeguatamente ridotti. Per ulteriori chiarimenti consultare il nostro ufficio tecnico. Ogni nostra responsabilità decade in caso di manomissioni o modifiche dei componenti.

• Stainless steel base in 1.4301 (1.4401 on specific request). Leveling element supplied with black non-skid plate in NBR rubber 70 shore. Stainless steel screw in 1.4301 (1.4401 on specific request). The leveling element could be supplied, on request, with steel nut.

• Load values above mentioned have to be considered referring to static conditions calculated at the half of the screw length. In conditions of vibrations or in presence of dynamic loads these values should be reduced. For further information consult our technical office. We cannot accept responsibility for mounts that have been tampered or modified

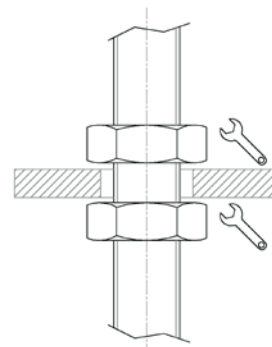
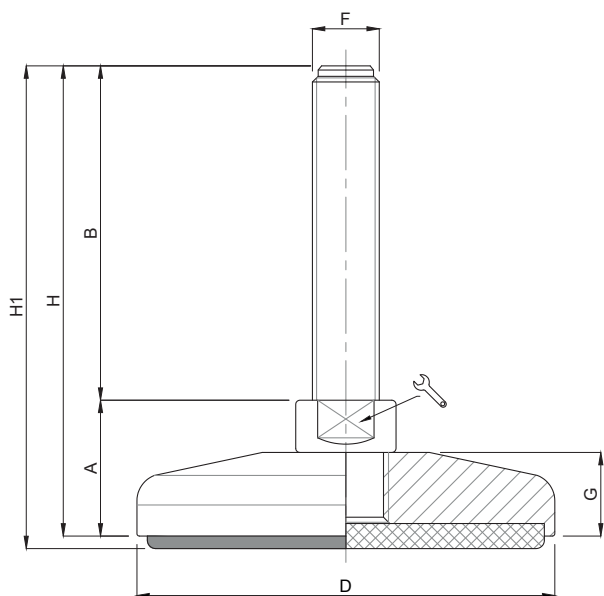

**ATTENZIONE:**  
Stelo non girevole.  
Utilizzare dado e controdado.  
Dado non fornito.

**ATTENTION:**  
Not pivoting stem.  
Use nut and locking nut.  
Nut not provided.

CODICE - CODE	descrizione	DIMENSIONI PRINCIPALI - MAIN DIMENSIONS							CARICO STATICO STATIC LOAD NEWTON
		A	B	D		F	G	H1	
11629	M16X100	33	100	Ø 100	20	M16	20	136	40000
11633	M16X150	33	150	Ø 100	20	M16	20	186	40000
11637	M16X200	33	200	Ø 100	20	M16	20	236	40000
11685	M20X100	33	100	Ø 100	20	M20	20	136	45000
11689	M20X150	33	150	Ø 100	20	M20	20	186	45000
11693	M20X200	33	200	Ø 100	20	M20	20	236	45000
11697	M20X250	33	250	Ø 100	20	M20	20	286	45000
11741	M24X100	34	100	Ø 100	20	M24	20	137	50000
* 11745	M24X150	34	150	Ø 100	20	M24	20	187	50000
* 11749	M24X200	34	200	Ø 100	20	M24	20	237	50000
11753	M24X250	34	250	Ø 100	20	M24	20	287	50000

\* Disponibile con Filettatura a passo fine. Aggiungere "/P2" al codice  
Available with Thin pitch thread. Please, add "/P2" to the code

• Materiale base: acciaio inox AISI 304 (a richiesta AISI 316). Elemento fornito con gomma antiscivolo NBR 70 shore. Materiale stelo: acciaio inox AISI 304 (a richiesta AISI 316). Su richiesta l'elemento di livellamento viene fornito con dado in acciaio.

• I valori dei carichi sopra riportati sono calcolati in condizioni statiche alla metà della lunghezza dello stelo filettato. Qualora s'intendesse utilizzare i supporti in presenza di vibrazioni o carichi in movimento, tali valori dovranno essere adeguatamente ridotti. Per ulteriori chiarimenti consultare il nostro ufficio tecnico. Ogni nostra responsabilità decade in caso di manomissioni o modifiche dei componenti.

• Stainless steel base in 1.4301 (1.4401 on specific request). Leveling element supplied with black non-skid plate in NBR rubber 70 shore. Stainless steel screw in 1.4301 (1.4401 on specific request). The leveling element could be supplied, on request, with steel nut.

• Load values above mentioned have to be considered referring to static conditions calculated at the half of the screw length. In conditions of vibrations or in presence of dynamic loads these values should be reduced. For further information consult our technical office. We cannot accept responsibility for mounts that have been tampered or modified

Caratteristiche: BASE DAL PIENO Ø 120, STELO FISSO

Features: SOLID BASE Ø 120, FIX STEM

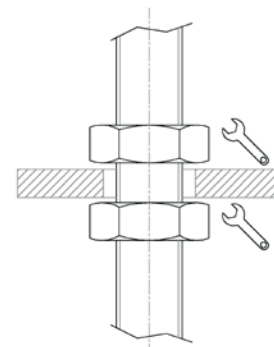
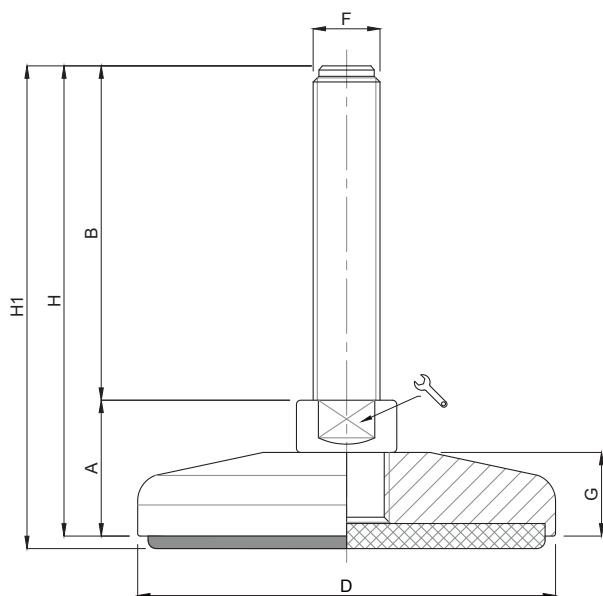

**ATTENZIONE:**  
Stelo non girevole.  
Utilizzare dado e controdado.  
Dado non fornito.

**ATTENTION:**  
Not pivoting stem.  
Use nut and locking nut.  
Nut not provided.

INOX

CODICE - CODE	descrizione	DIMENSIONI PRINCIPALI - MAIN DIMENSIONS							CARICO STATICO STATIC LOAD NEWTON
		A	B	D		F	G	H1	
antiscivolo - antislip	description								
11797	M20X100	35	100	Ø 120	20	M20	22	138	45000
11801	M20X150	35	150	Ø 120	20	M20	22	188	45000
11805	M20X200	35	200	Ø 120	20	M20	22	238	45000
11809	M20X250	35	250	Ø 120	20	M20	22	288	45000
11853	M24X100	35	100	Ø 120	20	M24	22	138	50000
* 11857	M24X150	35	150	Ø 120	20	M24	22	188	50000
* 11861	M24X200	35	200	Ø 120	20	M24	22	238	50000
11865	M24X250	35	250	Ø 120	20	M24	22	288	50000
11909	M30X100	36	100	Ø 120	26	M30	22	139	60000
* 11913	M30X150	36	150	Ø 120	26	M30	22	189	60000
* 11917	M30X200	36	200	Ø 120	26	M30	22	239	60000
11921	M30X250	36	250	Ø 120	26	M30	22	289	60000

\* Disponibile con Filettatura a passo fine. Aggiungere "/P2" al codice  
Available with Thin pitch thread. Please, add "/P2" to the code

- Materiale base: acciaio inox AISI 304 (a richiesta AISI 316). Elemento fornito con gomma antiscivolo NBR 70 shore. Materiale stelo: acciaio inox AISI 304 (a richiesta AISI 316). Su richiesta l'elemento di livellamento viene fornito con dado in acciaio.
- I valori dei carichi sopra riportati sono calcolati in condizioni statiche alla metà della lunghezza dello stelo filettato. Qualora s'intendesse utilizzare i supporti in presenza di vibrazioni o carichi in movimento, tali valori dovranno essere adeguatamente ridotti. Per ulteriori chiarimenti consultare il nostro ufficio tecnico. Ogni nostra responsabilità decade in caso di manomissioni o modifiche dei componenti.
- Stainless steel base in 1.4301 (1.4401 on specific request). Leveling element supplied with black non-skid plate in NBR rubber 70 shore. Stainless steel screw in 1.4301 (1.4401 on specific request). The leveling element could be supplied, on request, with steel nut.
- Load values above mentioned have to be considered referring to static conditions calculated at the half of the screw length. In conditions of vibrations or in presence of dynamic loads these values should be reduced. For further information consult our technical office. We cannot accept responsibility for mounts that have been tampered or modified

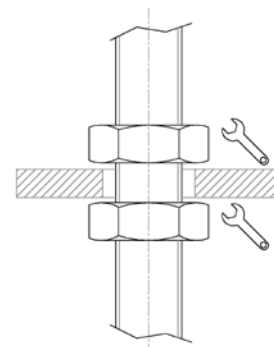
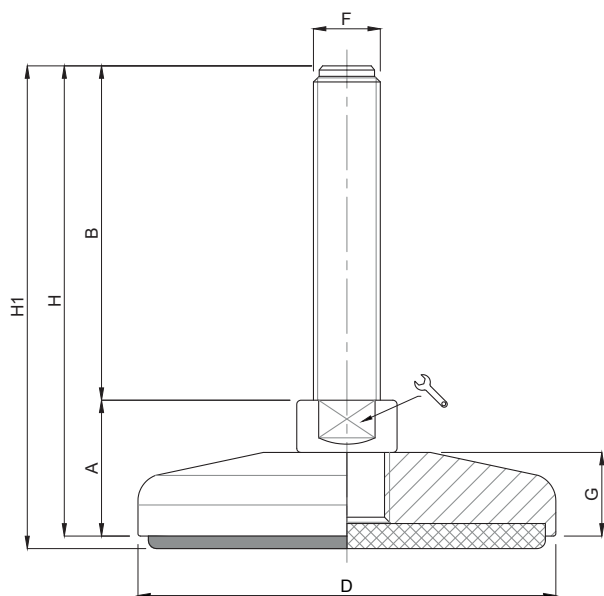

**ATTENZIONE:**  
Stelo non girevole.  
Utilizzare dado e controdado.  
Dado non fornito.

**ATTENTION:**  
Not pivoting stem.  
Use nut and locking nut.  
Nut not provided.

CODICE - CODE	descrizione description	DIMENSIONI PRINCIPALI - MAIN DIMENSIONS							CARICO STATICO STATIC LOAD NEWTON
		A	B	D		F	G	H1	
11965	M20X100	36	100	Ø 159	20	M20	23	139	50000
11969	M20X150	36	150	Ø 159	20	M20	23	189	50000
11973	M20X200	36	200	Ø 159	20	M20	23	239	50000
11977	M20X250	36	250	Ø 159	20	M20	23	289	50000
12021	M24X100	36	100	Ø 159	20	M24	23	139	60000
* 12025	M24X150	36	150	Ø 159	20	M24	23	189	60000
* 12029	M24X200	36	200	Ø 159	20	M24	23	239	60000
12033	M24X250	36	250	Ø 159	20	M24	23	289	60000
12077	M30X100	37	100	Ø 159	26	M30	23	140	70000
* 12081	M30X150	37	150	Ø 159	26	M30	23	190	70000
* 12085	M30X200	37	200	Ø 159	26	M30	23	240	70000
12089	M30X250	37	250	Ø 159	26	M30	23	290	70000

\* Disponibile con Filettatura a passo fine. Aggiungere "/P2" al codice  
Available with Thin pitch thread. Please, add "/P2" to the code

- Materiale base: acciaio inox AISI 304 (a richiesta AISI 316). Elemento fornito con gomma antiscivolo NBR 70 shore. Materiale stelo: acciaio inox AISI 304 (a richiesta AISI 316). Su richiesta l'elemento di livellamento viene fornito con dado in acciaio.
- I valori dei carichi sopra riportati sono calcolati in condizioni statiche alla metà della lunghezza dello stelo filettato. Qualora s'intendesse utilizzare i supporti in presenza di vibrazioni o carichi in movimento, tali valori dovranno essere adeguatamente ridotti. Per ulteriori chiarimenti consultare il nostro ufficio tecnico. Ogni nostra responsabilità decade in caso di manomissioni o modifiche dei componenti.
- Stainless steel base in 1.4301 (1.4401 on specific request). Leveling element supplied with black non-skid plate in NBR rubber 70 shore. Stainless steel screw in 1.4301 (1.4401 on specific request). The leveling element could be supplied, on request, with steel nut.
- Load values above mentioned have to be considered referring to static conditions calculated at the half of the screw length. In conditions of vibrations or in presence of dynamic loads these values should be reduced. For further information consult our technical office. We cannot accept responsibility for mounts that have been tampered or modified

Caratteristiche: BASE DAL PIENO Ø 100, STELO FISSO

Features: SOLID BASE Ø 100 WITH 2 BORES, FIX STEM

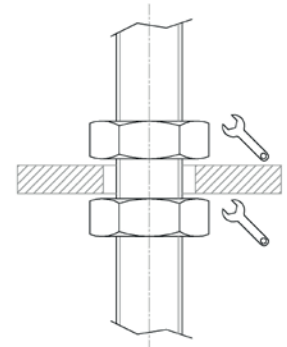
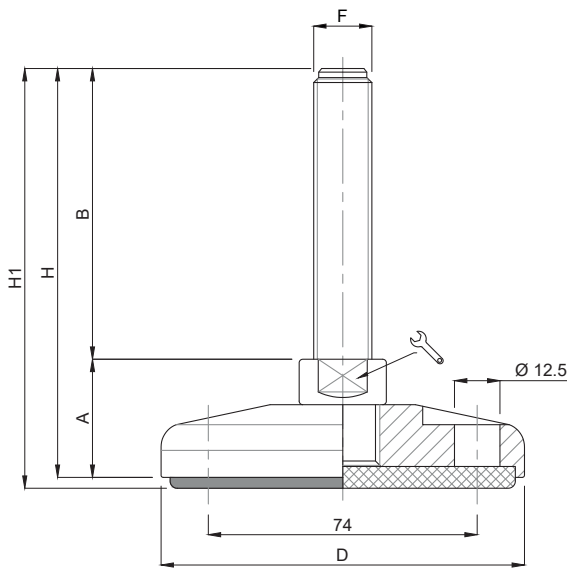

**ATTENZIONE:**  
Stelo non girevole.  
Utilizzare dado e controdado.  
Dado non fornito.

**ATTENTION:**  
Not pivoting stem.  
Use nut and locking nut.  
Nut not provided.

CODICE - CODE		descrizione description	DIMENSIONI PRINCIPALI - MAIN DIMENSIONS								CARICO STATICO STATIC LOAD NEWTON
standard standard	antiscivolo antislip		A	B	D	🔑	F	G	H	H1	
12132	12132/G	M16X100	33	100	Ø 100	20	M16	20	133	136	35000
12136	12136/G	M16X150	33	150	Ø 100	20	M16	20	183	186	35000
12140	12140/G	M16X200	33	200	Ø 100	20	M16	20	233	236	35000
12188	12188/G	M20X100	33	100	Ø 100	20	M20	20	133	136	40000
12192	12192/G	M20X150	33	150	Ø 100	20	M20	20	183	186	40000
12196	12196/G	M20X200	33	200	Ø 100	20	M20	20	233	236	40000
12200	12200/G	M20X250	33	250	Ø 100	20	M20	20	283	286	40000
12244	12244/G	M24X100	34	100	Ø 100	20	M24	20	134	137	45000
* 12248	12248/G	M24X150	34	150	Ø 100	20	M24	20	184	187	45000
* 12252	12252/G	M24X200	34	200	Ø 100	20	M24	20	234	237	45000
12256	12256/G	M24X250	34	250	Ø 100	20	M24	20	284	287	45000

\* Disponibile con Filettatura a passo fine. Aggiungere "IP2" al codice  
Available with Thin pitch thread. Please, add "IP2" to the code

- Per codice "/G" Gomma antiscivolo nera in NBR 70 Shore H6 non forata
- Materiale base: acciaio inox AISI 304 (a richiesta AISI 316). A richiesta disponibile con gomma antiscivolo NBR 70 shore (codice standard = senza gomma). Materiale stelo: acciaio inox AISI 304 (a richiesta AISI 316). Su richiesta l'elemento di livellamento viene fornito con dado in acciaio.
- I valori dei carichi sopra riportati sono calcolati in condizioni statiche alla metà della lunghezza dello stelo filettato. Qualora s'intendesse utilizzare i supporti in presenza di vibrazioni o carichi in movimento, tali valori dovranno essere adeguatamente ridotti. Per ulteriori chiarimenti consultare il nostro ufficio tecnico. Ogni nostra responsabilità decade in caso di manomissioni o modifiche dei componenti.
- Code "/G": black antislip pad NBR 70 shore H6 undrilled
- Stainless steel base in 1.4301 (1.4401 on specific request). On request anti-slip rubber 70 shore. Stainless steel screw in 1.4301 (1.4401 on specific request). The leveling element could be supplied, on request, with steel nut.
- Load values above mentioned have to be considered referring to static conditions calculated at the half of the screw length. In conditions of vibrations or in presence of dynamic loads these values should be reduced. For further information consult our technical office. We cannot accept responsibility for mounts that have been tampered or modified

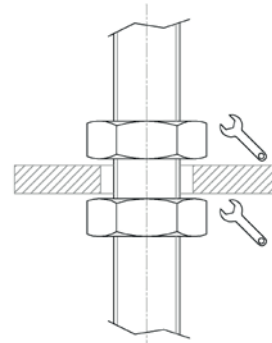
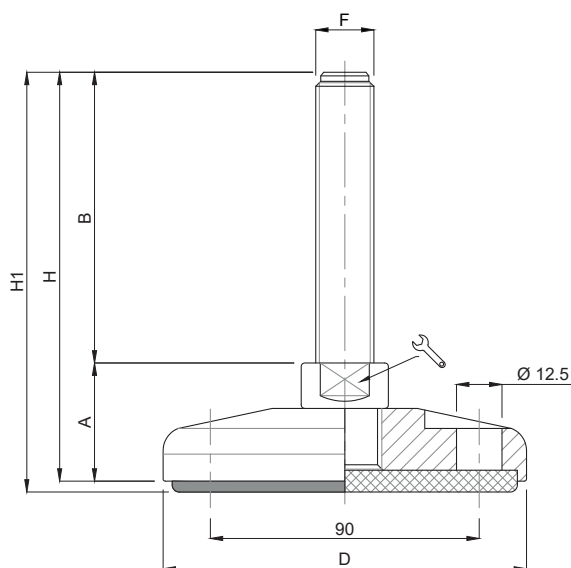

**ATTENZIONE:**  
Stelo non girevole.  
Utilizzare dado e controdado.  
Dado non fornito.

**ATTENTION:**  
Not pivoting stem.  
Use nut and locking nut.  
Nut not provided.

CODICE - CODE		descrizione description	DIMENSIONI PRINCIPALI - MAIN DIMENSIONS								CARICO STATICO STATIC LOAD NEWTON
standard standard	antiscivolo antislip		A	B	D		F	G	H	H1	
12356	12356/G	M20X100	35	100	Ø 120	20	M20	22	135	138	45000
12360	12360/G	M20X150	35	150	Ø 120	20	M20	22	185	188	45000
12364	12364/G	M20X200	35	200	Ø 120	20	M20	22	235	238	45000
12368	12368/G	M20X250	35	250	Ø 120	20	M20	22	285	288	45000
	12412	12412/G	36	100	Ø 120	20	M24	22	136	139	50000
*	12416	12416/G	36	150	Ø 120	20	M24	22	186	189	50000
*	12420	12420/G	36	200	Ø 120	20	M24	22	231	234	50000
	12424	12424/G	36	250	Ø 120	20	M24	22	281	284	50000
	12412/30	12412/30/G	36	100	Ø 120	26	M30	22	136	139	60000
*	12416/30	12416/30/G	36	150	Ø 120	26	M30	22	186	189	60000
*	12420/30	12420/30/G	36	200	Ø 120	26	M30	22	236	239	60000
	12424/30	12424/30/G	36	250	Ø 120	26	M30	22	286	289	60000

\* Disponibile con Filettatura a passo fine. Aggiungere "/P2" al codice  
Available with Thin pitch thread. Please, add "/P2" to the code

• Per codice "/G" Gomma antiscivolo nera in NBR 70 Shore H6 non forata

• Materiale base: acciaio inox AISI 304 (a richiesta AISI 316). A richiesta disponibile con gomma antiscivolo NBR 70 shore (codice standard = senza gomma). Materiale stelo: acciaio inox AISI 304 (a richiesta AISI 316). Su richiesta l'elemento di livellamento viene fornito con dado in acciaio.

• I valori dei carichi sopra riportati sono calcolati in condizioni statiche alla metà della lunghezza dello stelo filettato. Qualora s'intendesse utilizzare i supporti in presenza di vibrazioni o carichi in movimento, tali valori dovranno essere adeguatamente ridotti. Per ulteriori chiarimenti consultare il nostro ufficio tecnico. Ogni nostra responsabilità decade in caso di manomissioni o modifiche dei componenti.

• Code "/G": black antislip pad NBR 70 shore H6 undrilled

• Stainless steel base in 1.4301 (1.4401 on specific request). On request anti-slip rubber 70 shore. Stainless steel screw in 1.4301 (1.4401 on specific request). The leveling element could be supplied, on request, with steel nut.

• Load values above mentioned have to be considered referring to static conditions calculated at the half of the screw length. In conditions of vibrations or in presence of dynamic loads these values should be reduced. For further information consult our technical office. We cannot accept responsibility for mounts that have been tampered or modified

Caratteristiche: BASE DAL PIENO Ø 159, STELO FISSO

Features: SOLID BASE Ø 159 WITH 2 BORES, FIX STEM

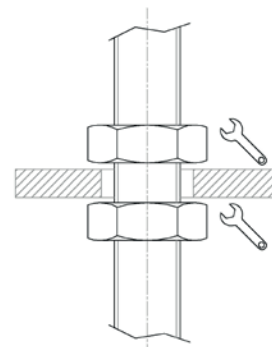
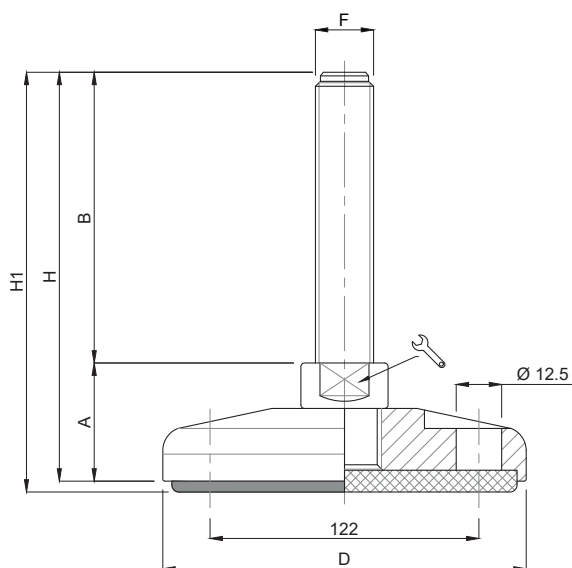

**ATTENZIONE:**  
Stelo non girevole.  
Utilizzare dado e controdado.  
Dado non fornito.

**ATTENTION:**  
Not pivoting stem.  
Use nut and locking nut.  
Nut not provided.

CODICE - CODE		descrizione description	DIMENSIONI PRINCIPALI - MAIN DIMENSIONS								CARICO STATICO STATIC LOAD NEWTON
standard standard	antiscivolo antislip		A	B	D		F	G	H	H1	
12468	12468/G	M20X100	36	100	Ø 159	20	M20	23	136	139	50000
12472	12472/G	M20X150	36	150	Ø 159	20	M20	23	186	189	50000
12476	12476/G	M20X200	36	200	Ø 159	20	M20	23	236	239	50000
12480	12480/G	M20X250	36	250	Ø 159	20	M20	23	286	289	50000
	12524	12524/G	37	100	Ø 159	20	M24	23	137	140	60000
*	12528	12528/G	37	150	Ø 159	20	M24	23	187	190	60000
*	12532	12532/G	37	200	Ø 159	20	M24	23	237	240	60000
	12536	12536/G	37	250	Ø 159	20	M24	23	287	290	60000
	12580	12580/G	37	100	Ø 159	26	M30	23	137	140	70000
*	12584	12584/G	37	150	Ø 159	26	M30	23	187	190	70000
*	12588	12588/G	37	200	Ø 159	26	M30	23	237	240	70000
	12592	12592/G	37	250	Ø 159	26	M30	23	287	290	70000

\* Disponibile con Filettatura a passo fine. Aggiungere "/P2" al codice  
Available with Thin pitch thread. Please, add "/P2" to the code

• Per codice "/G" Gomma antiscivolo nera in NBR 70 Shore H6 non forata

• Materiale base: acciaio inox AISI 304 (a richiesta AISI 316). A richiesta disponibile con gomma antiscivolo NBR 70 shore (codice standard = senza gomma). Materiale stelo: acciaio inox AISI 304 (a richiesta AISI 316). Su richiesta l'elemento di livellamento viene fornito con dado in acciaio.

• I valori dei carichi sopra riportati sono calcolati in condizioni statiche alla metà della lunghezza dello stelo filettato. Qualora s'intendesse utilizzare i supporti in presenza di vibrazioni o carichi in movimento, tali valori dovranno essere adeguatamente ridotti. Per ulteriori chiarimenti consultare il nostro ufficio tecnico. Ogni nostra responsabilità decade in caso di manomissioni o modifiche dei componenti.

• Code "/G": black antislip pad NBR 70 shore H6 undrilled

• Stainless steel base in 1.4301 (1.4401 on specific request). On request anti-slip rubber 70 shore. Stainless steel screw in 1.4301 (1.4401 on specific request). The leveling element could be supplied, on request, with steel nut.

• Load values above mentioned have to be considered referring to static conditions calculated at the half of the screw length. In conditions of vibrations or in presence of dynamic loads these values should be reduced. For further information consult our technical office. We cannot accept responsibility for mounts that have been tampered or modified